

# **Qwest Corporation Technical Publication**

## **Asynchronous Transfer Mode (ATM)**

**Copyright 1995, 1996, 1997, 1998, 1999, 2000, 2001,  
2002, 2003, 2004, 2005©**

**Qwest Corporation  
All Rights Reserved**

**77378**

**Issue I  
April 2005**



## NOTICE

This document describes Qwest Asynchronous Transfer Mode (ATM) Service offered by Qwest to its customers. The information provided in this document includes service features, technical specifications, performance objectives, and defines the valid User-Network Interfaces (UNIs).

Qwest Corporation reserves the right to revise this document for any reason, including but not limited to, conformity with standards promulgated by various governmental or regulatory agencies; utilization of advances in the state of the technical arts; or to reflect changes in the design of equipment, techniques, or procedures described or referred to herein.

Liability to anyone arising out of use or reliance upon any information set forth herein is expressly disclaimed, and no representation or warranties, expressed or implied, are made with respect to the accuracy or utility of any information set forth herein.

This document is not to be construed as a suggestion to any manufacturer to modify or change any of its products, nor does this publication represent any commitment by Qwest Corporation to purchase any specific products. Further, conformance to this publication does not constitute a guarantee of a given supplier's equipment and/or its associated documentation.

Future issues of Technical Publication 77378 will be announced to the industry at least 45 days prior to the issuance date. This notice, which will come through our standard customer notification channels, will allow the customer time to comment on the proposed revisions.

Ordering information for Qwest Publications can be obtained from the Reference Section of this document.

If further information is required, please contact:

Qwest Corporation  
Manager – New Services Planning  
700 W. Mineral Ave.  
Littleton, CO 80120

E-mail: [techpubs@qwest.com](mailto:techpubs@qwest.com)

Throughout this publication, the term Qwest signifies Qwest Corporation.



COMMENTS on PUB 77378

PLEASE SEND YOUR COMMENTS/SUGGESTIONS TO:

Qwest Corporation  
Manager – New Services Planning  
700 W. Mineral Ave.  
Littleton, CO 80120

E-mail: techpubs@qwest.com

Information from you helps us to improve our Publications. Please take a few moments to answer the following questions and return to the above address.

Was this Publication valuable to you in understanding The technical parameters of our service?	YES _____ NO _____
Was the information accurate and up-to-date?	YES _____ NO _____
Was the information easily understood?	YES _____ NO _____
Were the contents logically sequenced?	YES _____ NO _____
Were the tables and figures understandable and helpful	YES _____ NO _____
Were the pages legible?	YES _____ NO _____

If you answered NO to any of the questions and/or if you have any other comments or suggestions, please explain:

---

---

---

(Attach additional sheet, if necessary)

Name \_\_\_\_\_ Date \_\_\_\_\_

Company \_\_\_\_\_

Address \_\_\_\_\_

Telephone Number \_\_\_\_\_

E-Mail \_\_\_\_\_

## CONTENTS

<b>Chapter and Section</b>	<b>Page</b>
1. Introduction .....	1-1
1.1 General.....	1-1
1.2 Reason For Reissue.....	1-1
1.3 Purpose .....	1-1
2. Description of Service .....	2-1
2.1 Applicability of Technical Specifications.....	2-1
2.2 General Qwest ATM Service Description.....	2-1
2.2.1 Qwest ATM Service Permanent Virtual Connections .....	2-1
2.2.2 Qwest ATM Service Optical Access Link .....	2-2
2.2.3 Qwest ATM Service Optical Access Link Diversity .....	2-3
2.2.4 Qwest ATM Service Access Link .....	2-3
2.2.5 Qwest ATM Service Stand Alone Optical Access Link and Stand Alone Access Link.....	2-3
2.2.6 Qwest Inverse Multiplexing over ATM (IMA).....	2-3
2.2.7 Qwest ATM Service Point.....	2-4
2.2.8 Qwest ATM Service Port.....	2-4
2.2.8.1 Physical Layer Convergence Protocol (PLCP).....	2-4
2.2.8.2 Direct Mapping (DM) .....	2-4
2.2.9 Qwest ATM Service Equivalent Cell Rates .....	2-4
2.2.10 Qwest ATM Constant Bit Rate .....	2-5
2.2.11 Qwest ATM Variable Bit Rate .....	2-5
2.2.12 Qwest ATM Available Bit Rate .....	2-6
2.2.13 Qwest ATM Unspecified Bit Rate .....	2-6
2.2.14 Qwest Interworking PVC (IPVC).....	2-7
2.2.15 ATM Standards and Specifications.....	2-8
2.3 Qwest ATM Service PVC Overview.....	2-8
2.3.1 PVC Implementation .....	2-8
2.3.2 PVC Traffic Descriptors.....	2-10
2.3.3 Available PVC Increments.....	2-10
2.3.4 Individual Subscription Quantities And Throughput For CBR and VBR .....	2-10
2.3.5 Maximum Burst Size (MBS).....	2-11
2.3.6 Minimum Cell Rate (MCR).....	2-11
2.3.7 Available PVC Increments.....	2-11
2.3.8 Individual Subscription Quantities And Throughput For CBR and VBR .....	2-14

**CONTENTS (Continued)**

<b>Chapter and Section</b>	<b>Page</b>
2.4 Qwest ATM Service Architecture .....	2-15
2.4.1 EU Customer Provided Equipment (CPE) Data Terminal Equipment (DTE) Requirements.....	2-15
2.5 Qwest ATM Service Configuration .....	2-15
2.5.1 Qwest ATM Network And Service Points .....	2-16
2.5.2 Qwest ATM Service UNI.....	2-16
2.5.3 Single Wire Center Service Configuration.....	2-16
2.5.4 Multiple Wire Center Service Configuration.....	2-16
2.5.5 Non-Local Qwest ATM Service Point Service Configuration .....	2-17
2.5.6 Optical Access Link Diversity Service Configuration.....	2-17
2.5.7 Stand-Alone Optical Access Link and Stand-Alone Access Link Configuration.....	2-18
2.5.8 Interconnection and Collocation.....	2-18
3. Physical Layer.....	3-1
3.1 Description of Network Interfaces (NIs) for Qwest ATM Service.....	3-1
3.1.1 622.080 Mbps User Network Interface .....	3-1
3.1.2 155.520 Mbps User Network Interface.....	3-1
3.1.3 44.736 Mbps User Network Interface .....	3-1
3.1.4 1.544 Mbps User Network Interface .....	3-1
3.2 Network Interface (NI) Power Levels .....	3-2
3.3 NC and NCI Code Definitions .....	3-2
3.3.1 NC Code .....	3-2
3.3.2 NCI Code.....	3-2
3.3.3 Code Structure .....	3-2
3.3.4 Data Element.....	3-2
3.3.5 A = Alpha characters, A-Z .....	3-2
3.3.6 N = Numeric characters, 0-9 .....	3-2
3.4 Network Channel (NC) Format Structure.....	3-2
3.4.1 Channel Code.....	3-3
3.4.2 Optional Feature Code .....	3-3
3.5 NC Codes.....	3-3
3.5.1 NC Code Form.....	3-3
3.5.2 NC Code Components.....	3-4
3.5.3 Compatible NC Codes for the ATM Service 622.080 Mbps Optical Access Link.....	3-4

**CONTENTS (Continued)**

<b>Chapter and Section</b>	<b>Page</b>
3.5.4 Compatible NC Codes for the ATM Service 155.520 Mbps Optical Access Link.....	3-4
3.5.5 Compatible NC Codes for the ATM Service 44.736 Mbps Optical Access Link.....	3-5
3.5.6 Compatible NC Codes for the ATM Service 1.544 Mbps for Inverse Multiplexing over ATM (IMA).....	3-5
3.6 Network Channel Interface (NCI) Format Structure .....	3-5
3.6.1 Total Conductors.....	3-6
3.6.2 Protocol.....	3-6
3.6.3 Impedance .....	3-6
3.6.4 Protocol Options.....	3-6
3.6.5 Transmission Level Points (TLPs).....	3-7
3.6.6 The NCI Delimiter Usage.....	3-7
3.6.7 Applicable NCI Protocol Codes For ATM Service Optical Access Links.....	3-7
3.6.8 ATM Service 622.08 Mbps Optical Access Link NCI Codes at the Carrier Interface and IC-POP. ....	3-7
3.6.9 ATM Service 622.080 Mbps Optical Access Link NCI Codes at the EU-POT.....	3-7
3.6.10 ATM Service 155.520 Mbps Optical Access Link NCI Codes at the Carrier Interface and IC-POP .....	3-8
3.6.11 ATM Service 155.520 Mbps Optical Access Link NCI Codes at the EU-POT.....	3-8
3.6.12 ATM Service 44.736 Mbps Optical Access Link NCI Codes at the Carrier Interface and IC-POP .....	3-8
3.6.13 ATM Service 44.736 Mbps Optical Access Link NCI Codes at the EU-POT.....	3-8
3.6.14 Specifying NCI Codes for ATM Service Optical Access Links.....	3-8
3.6.15 Specifying NCI Codes for ATM Service Optical Access Links.....	3-9
3.7 Application of ATM Service with other Qwest Services.....	3-9
3.7.1 Qwest DS1 Service with Qwest ATM Service.....	3-9
3.7.2 Qwest DS3 Service with Qwest ATM Service.....	3-10
3.7.3 Qwest Self-Healing Alternate Route Protection with Qwest ATM Service.....	3-10

**CONTENTS (Continued)**

<b>Chapter and Section</b>	<b>Page</b>
3.7.4 Qwest Self Healing Network Service with Qwest ATM Service .....	3-10
3.7.5 Qwest Synchronous Service Transport with Qwest ATM Service .....	3-11
3.8 ATM CPE Card Information.....	3-11
4. ATM Layer Interface.....	4-1
4.1 General.....	4-1
4.2 Protocol Structure.....	4-1
4.3 Cell Structure .....	4-1
4.3.1 Generic Flow Control (GFC).....	4-2
4.3.2 Virtual Path Identifier (VPI) .....	4-2
4.3.3 Virtual Channel Identifier (VCI) .....	4-3
4.3.4 Payload Type Identifier (PTI) .....	4-3
4.3.5 Cell Loss Priority (CLP).....	4-3
4.3.6 Header Error Control (HEC) .....	4-3
4.4 Cell Rate Decoupling .....	4-3
5. Permanent Virtual Connection (PVC) Management.....	5-1
5.1 General.....	5-1
5.2 PVC Management Procedures .....	5-1
5.2.1 PVC Management Procedures at the UNI.....	5-1
5.3 Connection Admission Control (CAC) .....	5-1
5.4 Types of PVC Management Flows.....	5-2
5.4.1 Physical Layer OAM Information Flows.....	5-2
5.4.2 ATM Layer OAM Information Flows .....	5-3
5.5 ATM PVC Administration.....	5-4
6. Network Traffic Control and Congestion Management Responsibilities and Procedures.....	6-1
6.1 General.....	6-1
6.1.1 Purpose for Qwest ATM Service Network Traffic Control and Congestion Management Procedures.....	6-1
6.2 Network Traffic Control.....	6-1
6.2.1 Qwest ATM Service Network Traffic Control Procedures for CBR.....	6-2
6.2.2 Network Traffic Control Responsibilities for CBR.....	6-3

**CONTENTS (Continued)**

<b>Chapter and Section</b>	<b>Page</b>
6.2.3 Qwest ATM Service Network Traffic Control Procedures for VBR.....	6-3
6.2.4 Network Traffic Control Responsibilities for VBR.....	6-3
6.2.5 Qwest ATM Service Network Traffic Control Procedures for UBR .....	6-3
6.3 Network Congestion Management .....	6-5
6.3.1 Explicit Forward Congestion Indication (EFCI) .....	6-6
7. Performance Specifications .....	7-1
7.1 General.....	7-1
7.2 Objectives.....	7-1
7.2.1 Availability .....	7-1
7.3 Performance Parameters Definitions.....	7-2
8. Maintenance .....	8-1
8.1 Customer Responsibilities.....	8-1
8.2 QWEST Responsibilities.....	8-1
9. Definitions .....	9-1
9.1 Acronyms .....	9-1
9.2 Glossary .....	9-4
10. References.....	10-1
10.1 American National Standards Institute Documents.....	10-1
10.2 Telcordia (Bellcore) Documents .....	10-1
10.3 QWEST Documents.....	10-2
10.4 ATM Forum Documents .....	10-2
10.5 International Telecommunications Union (ITU) .....	10-2
10.6 Ordering Information .....	10-3
10.7 Trademarks .....	10-4
<b>Exhibits</b>	
2-1 Single Wire Center Configuration .....	2-18
2-2 Multiple Wire Center Configuration.....	2-19
2-3 Non-Local Qwest ATM Service Point Service Configuration (Private Line Service Option) .....	2-20
2-4 Optical Access Link Diversity Service Configuration.....	2-21
2-5 Stand-Alone Optical Access Link or Stand-Alone Cell Access Link Service Configuration.....	2-22
3-1 155.520 Mbps Interface EU Premises.....	3-13
3-2 44.736 Mbps Interface EU Premises.....	3-14

**CONTENTS (Continued)**

<b>Figures</b>		<b>Page</b>
2-1	Qwest ATM Service Protocol Relationships.....	2-1
2-2	Example of EU Networking Using Qwest ATM Service.....	2-9
3-1	Format Structure for NC Code.....	3-3
3-2	NCI Format Structure .....	3-6
4-1	ATM Cell Format.....	4-1

**Tables**

2-1	Traffic Parameters .....	2-10
2-2	Maximum MBS for Qwest ATM Service .....	2-11
2-3	Maximum Payload Rate of Offered Ports.....	2-12
2-4	Maximum Number of PVCs Per Port.....	2-12
2-5	Maximum Number of IMA VCCs Per Group.....	2-13
3-1	622.080 Mbps Access Compatible NC Codes.....	3-4
3-2	155.520 Mbps Access Compatible NC Codes.....	3-4
3-3	44.736 Mbps Access Compatible NC Codes.....	3-4
3-4	1.544 Mbps Access Compatible NC Codes for IMA.....	3-5
3-5	ATM Service NC/NCI Compatible Combinations.....	3-9
3-6	Compatible NC Codes for 1.544 Mbps Access.....	3-10
3-7	Compatible NCI Codes for 1.544 Mbps Access IMA.....	3-10
3-8	ATM CPE Options for 1.544 Mbps .....	3-11
3-9	ATM CPE Options for 44.736 Mbps .....	3-12
3-10	ATM CPE Options for UBR Service, all port speeds.....	3-12
4-1	Preassigned or Reserved Header Values.....	4-2
4-2	PTI Code Points .....	4-3
5-1	OAM Information Flows.....	5-2
5-2	Physical Layer OAM Functions .....	5-3
5-3	ATM Layer OAM Functions.....	5-3
7-1	Service Performance Parameters.....	7-3

## CONTENTS

<b>Chapter and Section</b>	<b>Page</b>
1. Introduction .....	1-1
1.1 General.....	1-1
1.2 Reason For Reissue.....	1-1
1.3 Purpose .....	1-1



## **1. Introduction**

### **1.1 General**

This document describes Qwest ATM Service offered by Qwest to its customers. The information provided in this document includes service features, technical specifications, performance objectives, and defines the valid User-Network Interfaces (UNIs).

### **1.2 Reason For Reissue**

- This document is being reissued to clarify CDVtol verbiage in Chapter 5.3, 6.2.1, 7.3, and Table 7.1. Table 2-4 has been updated to increase the DSL Host pvc's in limited areas.
- This document corrects the CAC acronym description in Sections 5.3, 9.1, and TOC.
- This document updates 2.2.15 with corrected FR Forum FRS 8.2, port definition, and Class of Service information, and removes reference to CES in 2.2.14.

### **1.3 Purpose**

The purpose of this document is to describe Qwest ATM Service. Sufficient technical information is furnished to allow a customer, for example, an End-User (EU), to select a service which may be incorporated into an end-to-end communications channel. It is not the intent of this document to provide specific ordering information, but to describe the technical features of this service offering.

## CONTENTS

Chapter and Section	Page
2. Description of Service .....	2-1
2.1 Applicability of Technical Specifications .....	2-1
2.2 General Qwest ATM Service Description .....	2-1
2.2.1 Qwest ATM Service Permanent Virtual Connections .....	2-2
2.2.2 Qwest ATM Service Optical Access Link .....	2-2
2.2.3 Qwest ATM Service Optical Access Link Diversity .....	2-3
2.2.4 Qwest ATM Service Access Link .....	2-3
2.2.5 Qwest ATM Service Stand Alone Optical Access Link and Stand Alone Access Link .....	2-3
2.2.6 Qwest Inverse Multiplexing over ATM (IMA) .....	2-3
2.2.7 Qwest ATM Service Point .....	2-4
2.2.8 Qwest ATM Service Port .....	2-4
2.2.8.1 Physical Layer Convergence Protocol (PLCP) .....	2-4
2.2.8.2 Direct Mapping (DM) .....	2-4
2.2.9 Qwest ATM Service Equivalent Cell Rates .....	2-4
2.2.10 Qwest ATM Constant Bit Rate .....	2-5
2.2.11 Qwest ATM Variable Bit Rate .....	2-5
2.2.12 Qwest ATM Available Bit Rate .....	2-6
2.2.13 Qwest ATM Unspecified Bit Rate .....	2-6
2.2.14 Qwest ATM/FR Interworking PVC (IPVC) .....	2-7
2.2.15 ATM Standards and Specifications .....	2-8
2.3 Qwest ATM Service PVC Overview .....	2-8
2.3.1 PVC Implementation .....	2-8
2.3.2 PVC Traffic Descriptors .....	2-10
2.3.3 Available PVC Increments .....	2-10
2.3.4 Individual Subscription Quantities And Throughput For CBR and VBR .....	2-10
2.3.5 Maximum Burst Size (MBS) .....	2-11
2.3.6 Minimum Cell Rate (MCR) .....	2-11
2.3.7 Available PVC Increments .....	2-11
2.3.8 Individual Subscription Quantities and Throughput For CBR and VBR .....	2-14
2.4 Qwest ATM Service Architecture .....	2-15
2.4.1 EU Customer Provided Equipment (CPE) Data Terminal Equipment (DTE) Requirements .....	2-15

## CONTENTS (Continued)

<b>Chapter and Section</b>	<b>Page</b>
2.5 Qwest ATM Service Configuration .....	2-15
2.5.1 Qwest ATM Network And Service Points .....	2-16
2.5.2 Qwest ATM Service UNI.....	2-16
2.5.3 Single Wire Center Service Configuration.....	2-16
2.5.4 Multiple Wire Center Service Configuration .....	2-16
2.5.5 Non-Local Qwest ATM Service Point Service Configuration .	2-17
2.5.6 Optical Access Link Diversity Service Configuration.....	2-17
2.5.7 Stand-Alone Optical Access Link and Stand-Alone Access Link Configuration.....	2-18
2.5.8 Interconnection and Collocation.....	2-18

### Figures

2-1 Qwest ATM Service Protocol Relationships.....	2-1
2-2 Example of EU Networking Using Qwest ATM Service.....	2-9

### Tables

2-1 Traffic Parameters .....	2-10
2-2 Maximum MBS for Qwest ATM Service .....	2-11
2-3 Maximum Cell Throughput of Offered Ports.....	2-12
2-4 Maximum Number of PVCs Per Port. ....	2-12
2-5 Maximum Number of VCCs Per IMA Group.....	2-13

### Exhibits

2-1 Single Wire Center Configuration .....	2-19
2-2 Multiple Wire Center Configuration.....	2-20
2-3 Non-Local Qwest ATM Service Point Service Configuration (Private Line Service Option) .....	2- <a href="#">2322</a>
2-4 Optical Access Link Diversity Service Configuration.....	2- <a href="#">2423</a>
2-5 Stand-Alone Optical Access Link or Stand-Alone Cell Access Link Service Configuration.....	2- <a href="#">2524</a>

## 2. Description of Service

### 2.1 Applicability of Technical Specifications

The technical specifications presented in this document are applicable to Qwest Asynchronous Transfer Mode Service (ATM) only. It is not the intent of this document to describe the various types of transmission equipment, switching equipment, and Network Management Systems (NMS) used to provide ATM Service. The service, as described in this document, pertains to the presently deployed transport, switching, and associated NMS technology. As further ATM hardware and software enhancements become available for network deployment, additional Qwest ATM Service features will be offered to the customer.

### 2.2 General Qwest ATM Service Description

Qwest ATM Service is a connection-oriented communications service that uses Asynchronous Transfer Mode technology to provide customers with high-speed, low delay networking capabilities. Qwest ATM Service is ideal for data intensive business computing applications that require near-real-time mixed media (e.g. data, video, image, & voice) communications among multiple locations.

Qwest ATM Service is implemented using the ATM cell transfer protocols running between Customer Provided Equipment (CPE) and the Qwest ATM Network. Figure 2-1 illustrates how the Qwest ATM Network performs only ATM and physical layer functions, while the customer's communication equipment is responsible for performing ATM Adaptation Layer (AAL) and higher layer protocol functions. Protocols running above the ATM layer (i.e., the cell payload) are passed transparently through the Qwest ATM Network.

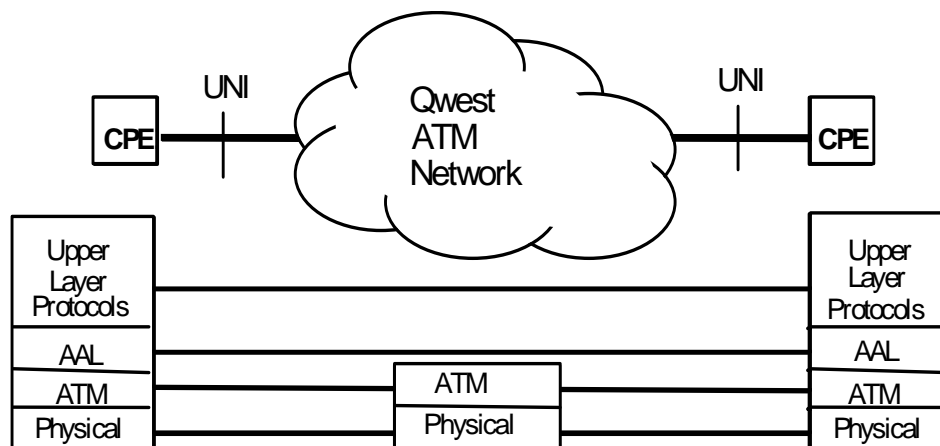

**Figure 2-1** Qwest ATM Service Protocol Relationships

ATM is a connection-oriented, cell-based switching technology. This technology provides high efficiency and flexibility because it provides multiple types of "virtual

channels or logical connections" instead of a single dedicated physical channel per application.

### **2.2.1 Qwest ATM Service Permanent Virtual Connections**

Qwest ATM Service utilizes logical connections referred to as Permanent Virtual Connections (PVCs). PVCs are relatively static and are established during the provisioning process. The User Network Interface (UNI) is the point at which a customer's data transmissions first enter the network supporting Qwest ATM Service. It is the point of interconnection between Qwest Communications facilities and customer provided equipment. Qwest ATM Service supports UNI physical interfaces of DS1 (1.544 Mbps), DS3 (44.736 Mbps), OC-3c (155.520 Mbps) and OC-12c (622.080 Mbps). The OC-12 interface will allow an individual PVC to have a maximum bandwidth of 149 Mbps.

Qwest ATM Service provides two types of logical PVCs: Virtual Channel Connections (VCCs) and Virtual Path Connections (VPCs). A VCC is a point to point logical connection between EU locations. Traffic parameters are assigned to each individual VCC. A VPC is a collection of VCCs routed together as one unit through the Qwest ATM public network. All VCCs carried within a VPC are switched within that VPC transparently by the Qwest ATM network. The customer must perform traffic shaping to ensure conformance with Qwest ATM Traffic Control Procedures (See Section 6). Constant Bit Rate (CBR, see Section 2.2.10) and Variable Bit Rate (VBR-rt, VBR-nrt see Section 2.2.11) traffic is provided over a VPC or a VCC. Available Bit Rate (ABR, see Section 2.2.12) and Unspecified Bit Rate (UBR, see Section 2.2.13) traffic is only offered as a VCC. Throughout this publication, the use of the term PVC refers to either of the two types: VCCs and/or VPCs.

### **2.2.2 Qwest ATM Service Optical Access Link**

A Qwest ATM Service Optical Access Link (OAL) provides access to the Qwest ATM Network, customer facilities at the User-Network Interface (UNI) over fiber-optic transport facilities. The transport facilities transfer information through the network over logical connections at speeds selected by the customer. The customer must designate which service category each logical connection will be: CBR, VBR-nrt, VBR-rt, ABR or UBR. A Qwest ATM Service Optical Access Link is only available at Qwest ATM Service Points. There are three types of OAL: 45 Mbps, 155 Mbps and 622 Mbps.

- The 622 Mbps OAL is offered as an unprotected circuit. The unprotected 622 Mbps OAL utilizes two fibers for transport. The 622 Mbps OAL delivers a 2-fiber optical interface to the customer.
- The 155 Mbps OAL is offered as an unprotected circuit or as a protected circuit. The unprotected 155 Mbps OAL utilizes two fibers for transport and the protected 155 Mbps OAL utilizes four fibers for transport. The 155 Mbps OAL delivers a 2-fiber optical interface to the customer.

- The 45 Mbps OAL is offered as an unprotected circuit or as a protected circuit. The unprotected 45 Mbps OAL utilizes two fibers for transport and the protected 45 Mbps OAL utilizes four fibers for transport. The 45 Mbps OAL delivers an electrical interface to the customer.

### **2.2.3 Qwest ATM Service Optical Access Link Diversity**

Two types of OAL, 45 Mbps and 155 Mbps are available with a path diversity option. OAL Diversity is provided over fiber optic facilities. This service provides a “standby” protect fiber path, which is routed over facilities separated, from the normal path, by 25 feet or more. Fiber optic facility separation is from the first utility vault outside the serving wire center to the last utility vault or hand hole prior to the customer’s premises. OAL Diversity is subject to availability of facilities. When facilities are not available, special construction charges may be assessed. Refer to section 2.5.6 on OAL Diversity.

### **2.2.4 Qwest ATM Service Access Link**

A Qwest ATM Service Access Link (ATM AL) provides DS1 physical access to the Qwest ATM Service Network, connecting customer facilities at the User-Network Interface (UNI) over DS1 Private Line transport facilities. The transport facilities transfer information through the network over logical connections at speeds selected by the customer. The customer must designate which service class each logical connection will be: CBR, VBR-nrt, or UBR. ABR and VBR-rt are currently not supported at a DS1 level according to ATM Forum Traffic Management 4.0 standards. A Qwest ATM Service Access Link is only available at Qwest ATM Service Points.

### **2.2.5 Qwest ATM Service Stand Alone Optical Access Link and Stand Alone Access Link**

A Qwest ATM Service Stand Alone Optical Access Link (SAOAL) and Stand Alone Access Link (SAAL) connects customer facilities to ATM networks provided by service providers other than Qwest. Private line transport mileage and/or a Central Office Connecting Channel (COCC) may be required in conjunction with a SAOAL or SAAL in order to connect the customer's serving wire center with the serving wire center of another ATM service provider. Qwest does not provide basic administration of PVCs on a SAOAL and SAAL.

### **2.2.6 Qwest Inverse Multiplexing over ATM (IMA)**

Qwest ATM service offers Inverse Multiplexing over ATM (IMA). This allows bandwidth increments between DS1 and DS3 levels using DS1 access links. IMA utilizes 2 to 8 DS1s and bundles them together to create a solid bandwidth increment of 3.045, 4.567, 6.090, 7.613, 9.135, 10.658 or 12.180 Mbps. IMA is available over the following classes of service; CBR, VBR-nrt, and UBR. ATM Forum IMA version 1.0 is the standard supported by Qwest ATM service.

### **2.2.7 Qwest ATM Service Point**

ATM Service Points are geographic locations designated by the Company where the Qwest ATM Network can be accessed. Service Points will be identified and disclosed at the Company's discretion in a publicly accessible Qwest Network Disclosure Announcement. An ATM Service Point doesn't necessarily signify that an ATM switch is placed in that location. The Qwest ATM service point includes the electronic equipment used in connecting the service elements to the Qwest ATM Network (i.e. the switch port) as well as any transport facilities required between the disclosed service point and an actual ATM switch location.

### **2.2.8 Qwest ATM Service Port**

ATM Service Ports are the physical entry points into the Qwest ATM Network for Optical Access Links or other compatible Private Line facilities, such as Synchronous Service Transport (SST), DS3 Service, or DS1 Service. They are the originating and terminating points for Virtual Path Connections and Virtual Channel Connections. The physical interface ports available are DS1, DS3, OC-3c and OC-12c.

Note that the customer must choose either Physical Layer Convergence Protocol (PLCP) cell mapping or Direct Mapped ATM cells across a DS3. The two mapping methods are incompatible because transmission path transceiver pairs must use the same mapping method.

#### **2.2.8.1 Physical Layer Convergence Protocol (PLCP)**

The PLCP method of mapping encapsulates ATM cells into a 125-microsecond frame inside the DS3 M-frame. A PLCP mapped DS3 provides a maximum cell rate of 96,000 cells/sec (40.704 Mbps).

#### **2.2.8.2 Direct Mapping (DM)**

Direct mapping of ATM cells is accomplished by directly inserting 53 byte ATM cells into the DS3 information payload. A Direct Mapped DS3 provides a maximum cell rate of 104,268 cells/sec (44.210 Mbps). The summary of maximum line rates is listed in Table 2-3.

### **2.2.9 Qwest ATM Service Equivalent Cell Rates**

Logical channels are established through the selection of cell rates and traffic descriptors. Qwest ATM Service offers the flexibility for customers to select different cell rates for each logical connection to match application needs. Therefore, the granularity of bandwidth choices for Qwest ATM Service exceeds bandwidth increments typically offered by private line services.

Since ATM efficiently transports voice, video and data traffic in a statistically multiplexed fashion, it is difficult to correlate the bandwidth of the various traffic types.

To support the QOS of a virtual connection, the Qwest network will use an equivalent cell rate to reserve the required bandwidth. For example, for a CBR connection the ECR will be high enough to support the PCR of the connection, and for a VBR connection, the Qwest network will reserve an ECR that supports bandwidth for both the SCR and the burst (MBS PCR). To arrive at a common basis for reserving bandwidth on an access link, the statistical characteristics of each traffic type is encapsulated in a concept called "Equivalent Cell Rate" (ECR).

Equivalent Cell Rate is a statistical method of arriving at the expected utilization of switching resources depending on the characteristic parameters of a PVC. For example, the ECR for a VBR circuit is dependent upon PCR, SCR and Maximum Burst Size (MBS). These factors combine to indicate the expected resource usage on the network. ECR is a simple and effective tool in determining the capacity that may be provisioned on an access link. (See 2.3.4)

### **2.2.10 Qwest ATM Constant Bit Rate**

Constant Bit Rate (CBR) traffic has been designed to support a connection carrying a constant flow of information. The ATM Forum refers to this type of information flow as Constant Bit Rate (CBR) traffic.

CBR is intended for real-time applications requiring tightly constrained delay and delay variation. The traffic associated with such applications is best characterized as information that is transmitted (and received) at a fixed, steady and reliable rate. A CBR PVC will be provisioned to provide end-to-end performance comparable to that typically associated with a digital private line. Qwest CBR service supports customer implemented Circuit Emulation Service (CES). The traffic parameter for a CBR PVC is the Peak Cell Rate (PCR). PCR specifies the highest cell rate a customer is provided on a connection. The PCR of a CBR PVC is used to calculate an ECR at an expected utilization of network resources for each PVC. The sum of all ECR PVCs must be less than the speed of the associated port. When ingress cells exceed the PCR for a CBR PVC, the cells are discarded upon entry into the Qwest ATM Network. CBR PVCs can be provisioned as VPCs or VCCs.

### **2.2.11 Qwest ATM Variable Bit Rate – real time and non real time**

Variable Bit Rate (VBR) has been designed to support a connection carrying information flowing at variable rates. The ATM Forum refers to this type of information as Variable Bit Rate (VBR) traffic. VBR has 2 types Variable Bit Rate real time (VBR-rt) and Variable Bit Rate non-real time (VBR-nrt). VBR-rt is for applications sensitive to delay and delay variation. VBR-nrt is for applications with less stringent requirements around delay and delay variation. Both types are “bursty”, but VBR-nrt does not require delay parameters.

For VBR connections, three traffic parameters describe the bandwidth characteristics. VBR parameters are the PCR, the Sustained Cell Rate (SCR) and the Maximum Burst Size (MBS). The customer selects the bandwidth characteristics of a VBR PVC by choosing the appropriate SCR and MBS. The PCR value will be set to:

- the smallest ATM port speed or 2 times SCR for VBR-rt (which ever is less)
- the smallest ATM port speed or 4 times SCR for VBR-nrt (which ever is less)

Using the PCR, SCR and MBS of each VBR PVC, an ECR is calculated to arrive at expected utilization of network resources. The sum of all PVC ECRs may equal, but not exceed, the speed of the associated port.

The SCR is an upper bound on the conforming average cell rate, as measured using the Generic Cell Rate Algorithm (GCRA) in accordance with the ATM Forum UNI 3.1, including bursts above the average, that can be sustained over a VBR PVC. For VBR connections the MBS may be 100, or 200 cells. Although a customer may send bursts of 100 or 200 cells over a VBR PVC, up to the PCR, the averaged cell rate transmitted for that PVC must not exceed the chosen SCR. Traffic shaping is to be performed at the customers CPE when provisioning service across a Qwest provisioned ATM Virtual Circuit Connection (VCC) or Virtual Path Connection (VPC). In the case of a VPC, the UPC and GCRA functions are based on the entire VPC, therefore failure to conform to Qwest ATM Network Traffic Control procedures will affect all traffic on the VPC.

Qwest VBR can be considered as the ATM Forum's VBR.1 definition outlined in Traffic Management Specification 4.0, Section 4.5.2 (VBR.1 section 4.5.2.1). The definition for VBR.1 states that CLP = 0+1 cells that conform to the traffic contract will be covered by the Cell Loss Ratio (CLR) guarantee. The tagging option is not applicable in the VBR.1 conformance definition, therefore non-conforming cells will be discarded at the ingress of the Qwest ATM network.

### **2.2.12 Qwest ATM Available Bit Rate**

Available Bit Rate (ABR) traffic has been designed to support a connection carrying a specific amount of data. The source rate is controlled by a flow control mechanism of Resource Management (RM) cells. These RM cells control the flow of traffic over the ABR PVC to ensure a low cell loss ratio and maintain a specific minimum bandwidth through the network. ABR parameters include PCR and Minimum Cell Rate (MCR). MCR will automatically be set to 10% of the customer specified PCR. The bandwidth available to the ABR service can vary up to PCR, but will not go below MCR. ABR is not for real time applications. It is for applications that will tolerate variable bandwidth with a minimum limit that the necessary bandwidth cannot fall below. ABR PVCs can only be provisioned as VCCs.

### **2.2.13 Qwest ATM Unspecified Bit Rate**

Unspecified Bit Rate (UBR) is a "best effort" service designed to support connections that transmit and receive at uneven rates, i.e., applications not requiring tightly constrained delay, delay variation, and cell loss. Examples of such applications are traditional computer communications applications, such as file transfer and email, typically using TCP/IP. The ATM Forum refers to this type of information as Unspecified Bit Rate (UBR) traffic.

UBR does not specify traffic related service guarantees. Qwest does not make service level commitments with respect to the overall cell loss ratio experienced by a UBR connection, or as to the cell transfer delay experienced by cells on the connection.

The traffic descriptor for UBR connections is defined by the PCR. Since no numerical commitments are made on UBR connections there is no corresponding ECR identified for network resource utilization. Unlike CBR, VBR, and ABR, UBR PVCs are not considered in the summation of bandwidth over a port, although each UBR PVC will be taken in account when determining the maximum allowable number of PVCs across a port. UBR connections can be provisioned only as VCCs.

#### **2.2.14 Qwest ATM/FR Interworking PVC (IPVC)**

Qwest IPVC creates a connection between the ATM network and Frame Relay network. ATM to Frame Relay interworking is an option that allows customers to complement the high-bandwidth transport capabilities of ATM with the cost-effective, narrowband data transport of frame relay in order to provide a seamless transition to a single, multiservice network. The interworking function is based on FRF8.2 Frame Relay/ATM PVC Service Interworking Implementation Agreement from the Frame Relay Forum.

A customer frame relay location connects to a frame relay port via a frame relay User-Network Interface (UNI) and, correspondingly, the customer ATM location connects to the ATM port via an ATM UNI. A frame relay PVC is provisioned from the frame relay customer location to the Interwork Function and an ATM VCC is provisioned from the ATM customer location to the Interwork Function. The Interworking Function connects the FR PVC to the ATM PVC and maps frames to cells and cells to frames. The Frame Relay to ATM PVCs are provisioned in translation mode which means that RFC 1490 encapsulated frames are translated into RFC 1483 encapsulated frames and vice versa.

### **2.2.15 ATM Standards and Specifications**

ATM Service is based on the following documents:

- TA-TSV-001408, Generic Requirements for PVC Cell Relay Service, Telcordia, Technical Advisory.
- SR-3330, Cell Relay Service Core Features, Telcordia, Special Report.
- SR-3445, Requirements for PVC Cell Relay Service, Telcordia, Special Report.
- ATM Forum, ATM User Network Interface Specification, Version 3.1, Prentice-Hall 1994.
- ATM Forum, Traffic Management Specification, Version 4.0, The ATM Forum 1996.
- ATM Forum, DS1 Physical Layer Specification, The ATM Forum 1994.
- ATM Forum, DS3 Physical Layer Interface Specification, The ATM Forum 1996.
- ANSI T1.511, B-ISDN ATM Layer Cell Transfer - Performance Parameters.
- GR-1113-CORE, Asynchronous Transfer Mode (ATM) and ATM Adaptation Layer (AAL) Protocols, Telcordia.
- GR-1248-CORE, Generic Requirements for Operations of ATM Network Elements, Telcordia.
- GR-1117-CORE, Generic Requirements for Exchange PVC CRS Service, Telcordia.
- TR-NWT-001112, Broadband ISDN User to Network Interface and Network Node Interface Physical Layer Generic Criteria, Telcordia.

## **2.3 Qwest ATM Service PVC Overview**

Qwest ATM Service is a connection-oriented communications service that uses ATM to provide customers with high-speed, low delay networking capabilities. Qwest ATM Service is ideal for data intensive business computing applications that require near-real-time mixed media (e.g. data, video, image, & voice) communications among multiple locations. Qwest ATM Service has been implemented utilizing PVCs only.

### **2.3.1 PVC Implementation**

PVCs are logical connections that define a specific transmission path between a Data Terminal Equipment (DTE) source device and a DTE destination device. Qwest ATM Service provides two types of PVCs: VPCs and VCCs. A Qwest ATM Service PVC, which is similar to a dedicated private line in today's circuit switched environment, is identified in the Qwest ATM Network by Virtual Path Identifiers (VPI) and Virtual Channel Identifiers (VCI). Each VPI and VCI is located within the five byte header of the standard ATM cell format, which is described in Chapter 4.

PVC implementation with Qwest ATM Service permits a customer to define logical connections among multiple EU locations using a single port per location. Simultaneous connectivity to many remote locations can be established through the provisioning of multiple PVC's. Figure 2-2 illustrates the connectivity capability available with the Qwest ATM Service PVC offering.

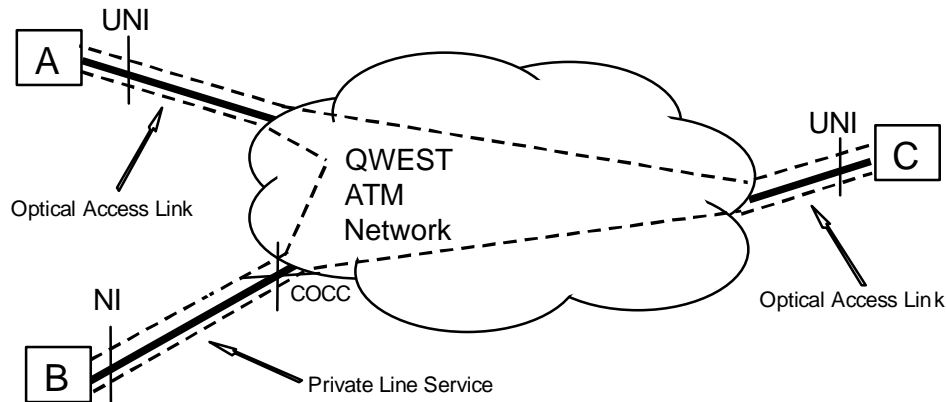

**Figure 2-2** Example of EU Networking Using Qwest ATM Service

Figure 2-2 shows three customer locations (A, B, and C) logically connected using PVC implementation with Qwest ATM Service. Customers A and C are connected to the Qwest ATM Network via Optical Access Links. Customer B is connected to the Qwest ATM Network via a Private Line Service and Central Office Connecting Channel. Solid lines represent the connections to the Qwest ATM Network. The dashed lines represent a mesh of logical connections that can be supported across the access links using the native-mode ATM protocol. The logical connections shown in this example facilitate point-to-point communications between pairs of locations (i.e., A and B, A and C, or B and C).

### 2.3.2 PVC Traffic Descriptors

Qwest ATM Service traffic descriptors are based on ATM Forum specifications. Table 2-1 indicates the traffic descriptors for each of the Service Categories. The traffic parameters are defined following Table 2-1.

**Table 2-1** Traffic Descriptors

<b>Service Categories</b>	<b>Traffic Descriptors(s)</b>
Constant Bit Rate	Peak Cell Rate (PCR) Cell Delay Variation Tolerance (CDVT)
Variable Bit Rate – real time (VBR-rt)	Peak Cell Rate (PCR), Sustained Cell Rate (SCR), Maximum Burst Size (MBS) Cell Delay Variation Tolerance (CDVT)
Variable Bit Rate – non real time (VBR-nrt)	Peak Cell Rate (PCR), Sustained Cell Rate (SCR), Maximum Burst Size (MBS) Cell Delay Variation Tolerance (CDVT)
Available Bit Rate	Peak Cell Rate (PCR), Minimum Cell Rate (MCR) Cell Delay Variation Tolerance (CDVT)
Unspecified Bit Rate	Peak Cell Rate (PCR) Cell Delay Variation Tolerance (CDVT)

### 2.3.3 Peak Cell Rate (PCR)

The PCR traffic parameter specifies an upper bound on the cell rate that can be submitted across a connection. According to standards, PCR is required for CBR, VBR, ABR and UBR PVCs.

### 2.3.4 Sustained Cell Rate (SCR)

The SCR defines an upper bound on the conforming average cell rate of a connection (i.e. rate averaged over a time interval). Along with PCR and Maximum Burst Size (MBS), SCR is used to describe a VBR PVC. The SCR is an upper bound on the conforming average cell rate, as measured using the Generic Cell Rate Algorithm (GCRA) in accordance with the ATM Forum UNI 3.1, including bursts above the average, that can be sustained over a VBR PVC. Provisioning of this limit requires

allocation of sufficient network resources to meet the SCR and MBS, but less than those based on the PCR.

### 2.3.5 Maximum Burst Size (MBS)

Maximum Burst Sizes of 100 or 200 cells will be used for Qwest ATM Service (Table 2-3). MBS of 100 cells is the default. MBS is the maximum number of cells a customer may burst up to the peak cell rate. This parameter only applies to Variable Bit Rate real time and non-real time classes of service. With this allowable burst, a customer must still maintain an overall average cell rate at SCR.

**Table 2-2** Maximum MBS for Qwest ATM Service

Maximum Burst Size (MBS) of Virtual Channel Connection (VCC)
100 cells (default)
200 cells

### 2.3.6 Minimum Cell Rate (MCR)

The MCR defines a minimum bound on the cell rate of a connection. MCR is used to describe an ABR PVC along with the PCR parameter. Bandwidth can vary between PCR and MCR depending on network availability, but cannot go below MCR. The MCR is a minimum bound on the conforming average cell rate, as measured using the Generic Cell Rate Algorithm (GCRA) in accordance with the ATM Forum UNI 3.1.

### 2.3.7 Available PVC Increments

At service subscription time, each Qwest ATM Service customer may request multiple VPCs and/or VCCs per port. Before provisioning a PVC, the customer must identify the desired Cell Transfer Rate (CTR). The CTR will be mapped to the appropriate traffic parameters (PCR, SCR, MCR, MBS, etc) associated the customer's desired class of service (CBR, VBR, ABR, UBR). For CBR, ABR and UBR, the CTR maps to PCR. Then for the ABR service, MCR will be set in relation to the PCR (see section 2.2.12). For VBR the CTR maps to SCR. Cell throughput includes ATM overhead added by customer provided equipment (i.e. ATM cell header and AAL header information). For this reason, the access line speed will be greater than the total customer payload throughput over the access link. Table 2-3 outlines the maximum cell throughput over an access link in megabits per second and cells per second. The maximum number of PVCs (VPCs and VCCs) allowed over a Qwest ATM access line is stated in Table 2-4.

**Table 2-3** Approximate Maximum Cell Throughput of Offered Ports

Port Interface	Approximate Maximum Cell Throughput (Mbps)	Maximum Cell Throughput (cells/s)
DS1	N=1-23 increments of 64 kbps	N x 151
	N=1-20 increments of 75 kbps***	N x 177
	N=1 increment of 1MB *	2359
	N=1 increment of 1.536 **	3,622
	N=1 increment of 1.787***	4215
IMA	3.045	7,182
	4.567	10,773
	6.090	14,364
	7.613	17,955
	9.135	21,546
	10.658	25,137
	12.180	28,728
PLCP DS3	40.704	96,000
Direct Mapped DS3	44.210	104,268
OC-3c	149.760	353,207
OC12c	599.041	1,412,830

\* Increments of 1 MB available on interfaces of DS1 up to OC12.

\*\* Increments of 1.536 Mbps available on DS1 interface only.

\*\*\* In support of customer based CES CPE over CBR service

**Table 2-4** Maximum Number of PVCs Per Port.

Line Rate	Maximum Number of VPCs per Qwest ATM Port	Maximum Number of VCCs per Qwest ATM Port	Maximum Number of VCCs per Qwest DSL Host Port *
1.544 Mbps	5	220	220
44.736 Mbps	50	2000	2000 / (3000 *)
155.520 Mbps	200	3000	3000
622.080 Mbps	200	4000	4000

\*Limited Availability – please see Qwest Network Disclosure located at <http://www.qwest.com/disclosures>

**Table 2-5** Maximum Number of VCC's Per IMA group

Port Interface	Approximate Maximum Payload Rate (Mbps)	Maximum Number of VCCs per Qwest IMA Port
IMA Nx2 DS1	3.045	330
IMA Nx3 DS1	4.567	440
IMA Nx4 DS1	6.090	550
IMA Nx5 DS1	7.613	660
IMA Nx6 DS1	9.135	770
IMA Nx7 DS1	10.658	880
IMA Nx8 DS1	12.180	990

### 2.3.8 Individual Subscription Quantities And Throughput For CBR and VBR

Each Qwest ATM Service customer with multiple CBR, VBR and UBR VPCs and/or VCCs provisioned on a single port must consider the maximum throughput achievable. UBR PVCs are not considered in determining achievable throughput. Using the calculated ECR for each PVC, the maximum achievable throughput for all CBR and VBR PVCs provisioned on a given port can be determined by completing the following calculations.

Maximum achievable throughput across a DS1 with multiple PVCs:

$$\sum \text{ECR of all PVCs} < 3,622 \text{ cells/s}$$

Maximum achievable throughput across an ATM IMA with multiple PVCs:

$$\sum \text{ECR of all PVCs} < 3,591 \text{ cells/s} \times N, \text{ where } N = \text{Number of IMA links}$$

Maximum achievable throughput across a PLCP Mapped DS3 with multiple PVCs:

$$\sum \text{ECR of all PVCs} < 96,000 \text{ cells/s}$$

Maximum achievable throughput across a Direct Mapped DS3 with multiple PVCs:

$$\sum \text{ECR of all PVCs} < 104,268 \text{ cells/s}$$

Maximum achievable throughput across an OC-3c with multiple PVCs:

$$\sum \text{ECR of all PVCs} < 353,207 \text{ cells/s}$$

where ECR = Equivalent Cell Rate

PVC = Permanent Virtual Connections (VPCs and/or VCCs)

An example is provided which may help clarify the above calculations. A customer has subscribed to a PLCP Mapped DS3 Qwest ATM Service, with the following CBR and VBR PVCs:

VCC with 10 Mbps SCR, 32 cells MBS, VBR

VCC with 1.536 Mbps PCR, CBR

VCC with 6 Mbps SCR, 100 cells MBS, VBR

VPC with 5 Mbps PCR, CBR

Calculations using available increments in cells/s:

$$\sum \text{ECR of all PVCs} < 96,000 \text{ cells/s}$$

$$[26,880] + [3,622] + [(2 \times 9,600)] + [(5 \times 2,358)] < 96,000 \text{ cells/s}$$

$$[26,880] + [3,622] + [19,200] + [11,795] < 96,000 \text{ cells/s}$$

$$61,497 \text{ cells/s} < 96,000 \text{ cells/s}$$

Therefore, the above PVCs could be provisioned over a PLCP DS3.

## **2.4 Qwest ATM Architecture**

Qwest ATM Service establishes logical connectivity between the customer devices, using PVCs (VPCs and/or VCCs) which can be multiplexed over a single access path. The Qwest ATM Network Architecture which supports and administers the Qwest ATM Service Points, access links, ports and the virtual connections consists of the following elements:

- Private Line facilities or fiber optic facility used to access the Qwest ATM Network.
- Ports located at Qwest ATM Service Points.
- ATM Service Points located at Qwest Wire Centers.
- Digital Inter-Office Facilities (IOF) between Qwest ATM Service Points.
- Qwest Network Administration and Monitoring Systems.

### **2.4.1 EU Customer Provided Equipment (CPE) Data Terminal Equipment (DTE) Requirements**

The EU's CPE Data Terminal Equipment (DTE) device accumulates customer traffic (e.g., LAN traffic, host computer, voice, video, multimedia), and inserts the customer data into an ATM format suitable for transmission over the Qwest ATM Network (i.e., using ATM cell transfer protocols). The Network performs only ATM and physical layer functions, while the customer's communication equipment is responsible for performing AAL and higher layer protocol functions. Protocols running above the ATM layer (i.e., the cell payload) are passed transparently through the Qwest ATM Network. The ATM switch port provides access to the network for transport. Recommended customer CPE DTE options and the Qwest ATM Service physical UNIs are addressed in Chapter 3.

## **2.5 Qwest ATM Service Configuration**

The purpose of this section is to describe some of the typical service configurations associated with Qwest ATM Service. Qwest ATM Service may utilize both interoffice and local loop facilities to support the transport of Qwest ATM Service customer traffic. The Qwest ATM Service customer can access the Qwest ATM Network via Qwest ATM Service Optical Access Links, or Private Line facilities. Private Line facilities are required when the customer premises' Serving wire center is not a Qwest ATM Service Point. Qwest ATM Service ports are the physical entry points into the Qwest ATM Network for Optical Access Links or other compatible private line facilities and are the originating and terminating points for VPCs and VCCs. Customers can allocate bandwidth to applications at customer-designated transmission speeds of up to their subscribed port.

### **2.5.1 Qwest ATM Network And Service Points**

The Qwest ATM Network is considered to consist of Service Points, ports, access lines, and Interoffice Facilities (IOF). Qwest IOF will be utilized to transport Qwest ATM Service traffic between Service Points within the same Local Access and Transport Area (LATA).

Qwest will place ATM switching equipment and designate certain wire centers as service points to support Qwest ATM Service.

If the Qwest serving wire center for a customer is not a service point, Qwest ATM Service access may be provided via:

- A customer ordered Private Line Service (i.e. DS1, DS3, SST), interoffice facilities, and Central Office (CO) terminations (e.g., CO connecting channels). See Subsection 2.6.5, Exhibit 2-3, and Section 3.8 for further details on this specific service configuration.

### **2.5.2 Qwest ATM Service UNI**

The EU UNI is the point at which a customer's data transmissions first enter the network supporting Qwest ATM Service. It is the point of interconnection between Qwest's facilities and customer terminal equipment. The UNIs offered to the customers will be at the following physical interfaces: DS1 (1.544 Mbps), (IMA 3.072, 4.608, 6.144, 7.680, 9.216, 10.752 and 12.288 Mbps), DS3 (44.736 Mbps), OC-3c (155.520 Mbps) and OC12c (622.080 Mbps). Chapter 4 of this document describes the protocol structure of the ATM Layer. The customer's physical interfaces for Qwest ATM Service are described in Chapter 3. The UNI for signaling and its data transfer protocol are specified in the ATM Forum User Network Interface Specification 3.1. The Qwest ATM Service Optical Access Link(s) that terminate on the customer's UNI may be provided over an existing Qwest Fiber Optic Facility.

### **2.5.3 Single Wire Center Service Configuration**

A single wire center configuration, shown in Exhibit 2-1, will support multiple Qwest ATM Service customers whose nearest Qwest ATM Service Point is located within the same serving wire center. It is possible to subscribe to multiple PVCs per ATM port to provide multiple VPCs/VCCs for the customer.

A single wire center configuration consists of the following:

- Single Qwest ATM Service Point
- Multiple ATM ports and access line connections

### **2.5.4 Multiple Wire Center Service Configuration**

A multiple wire center configuration, shown in Exhibit 2-2, will support multiple Qwest ATM Service customers whose nearest Qwest ATM Service Points are located at different serving wire centers.

A multiple wire center service configuration consists of the following:

- Multiple Qwest ATM Service Points
- Multiple ATM ports and access line connections
- Trunks between ATM Service Nodes

### **2.5.5 Non-Local Qwest ATM Service Point Service Configuration**

A service configuration in which the customer's serving wire center is not a Qwest ATM Service Point is shown in Exhibit 2-3. When a customer's serving wire center is not a Qwest ATM Service Point the customer may have the following option:

- Utilize a combination of a Qwest ATM Service port, access line, a Central Office Connecting Channel, and customer ordered, Company-provided Private Line Services (i.e. DS1, DS3, SST) to reach the nearest Qwest ATM Service Point. If a customer utilizes Private Line Services to access Qwest ATM Service, the associated regulations, rates and charges for such Private Line Services shall apply in addition to the rates and charges associated with the Qwest ATM Service elements. See Exhibit 2-3 and Section 3.7.

A Non-Local Qwest ATM Service Point service configuration may consist of the following:

- A customer's serving wire center, which is not a Service Point.
- A Private Line Service (DS1, DS3, or SST).
- CO Connecting Channels.
- An Interoffice Facility.
- Multiple ATM ports and access line connections

### **2.5.6 Optical Access Link Diversity Service Configuration**

A Qwest ATM Service OAL Diversity service configuration, shown in Exhibit 2-4, provides a “standby” protect fiber path, which is routed over facilities separated, from the normal path, by 25 feet or more. Fiber optic facility separation is from the first utility vault outside the serving wire center to the last utility vault or hand hole prior to the customer’s premises.

An OAL Diversity service configuration consists of the following:

- A customer's nearest serving wire center.
- A Qwest ATM Service OAL.
- A “Normal” fiber path.
- A “Protect” fiber path.

### **2.5.7 Stand Alone Optical Access Link and Stand Alone Access Link Configuration**

A Qwest ATM Service SAOAL or SAAL service configuration, shown in Exhibit 2-5, provides access to ATM networks provided by service providers other than Qwest. Private line transport mileage and/or a COCC may be required in order to connect the customer's serving wire center, with the serving wire center, of another ATM Service provider. Qwest does not provide administration of PVCs on a SAOAL or SAAL.

A SAOAL or SAAL service configuration consists of the following:

- A customer's nearest serving wire center, which may or may not be a Qwest ATM Service Point.
- A Qwest ATM SAOAL or SAAL.
- May or may not include a COCC and private line transport mileage.

### **2.5.8 Interconnection and Collocation**

The expanded Interconnection and Collocation Channel Termination (EICT) is available for DSL Host and ATM Services. Further information about the EICT may be found in Qwest Technical Publication 77386, "Expanded Interconnection and Collocation for Private Line Transport and Switched Access Services".

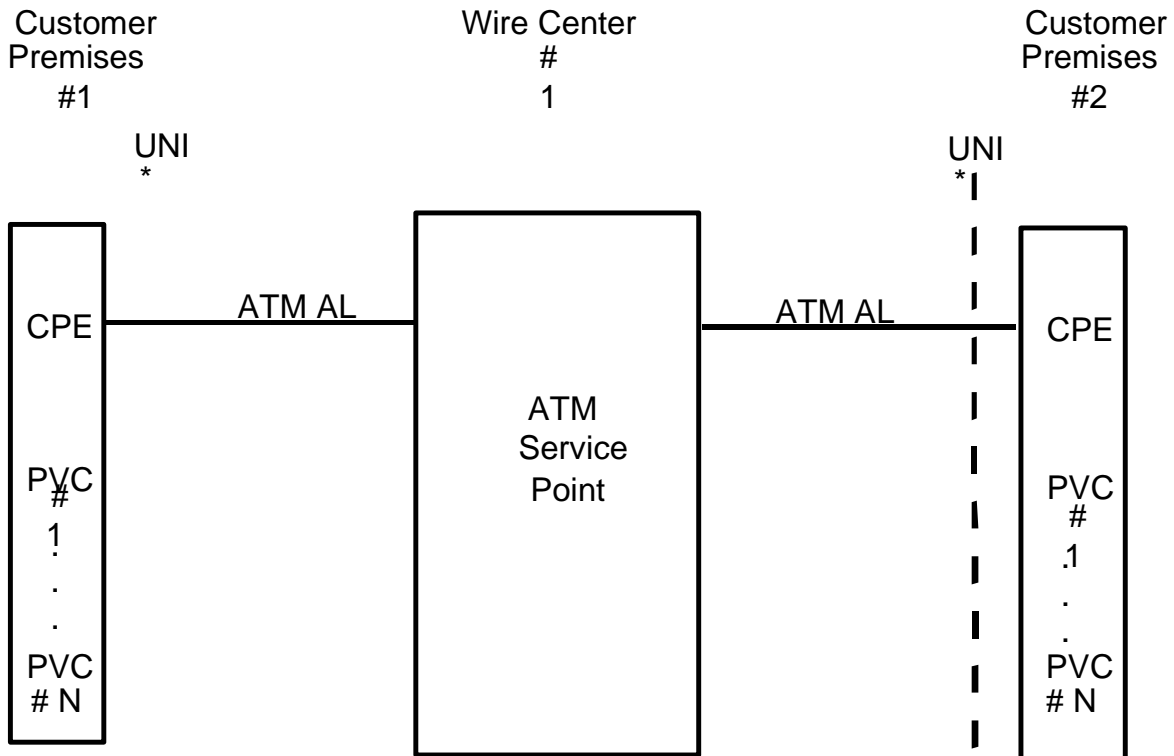

For value of N, please refer to table 2-4

Qwest ATM Service EU customer traffic will exchange information at the UNI. This is based on the PVC signalling of UNI defined \* in the ATM Forum User Network Interface Specification 3.1 (1994).

<b>LEGEND:</b>
CPE Customer Provided Equipment
ATM AL - ATM Access Link
UNI - User Network Interface
PVC Permanent Virtual Circuit
VPC - Virtual Path Connection

**Exhibit 2-1** Single Wire Center Configuration

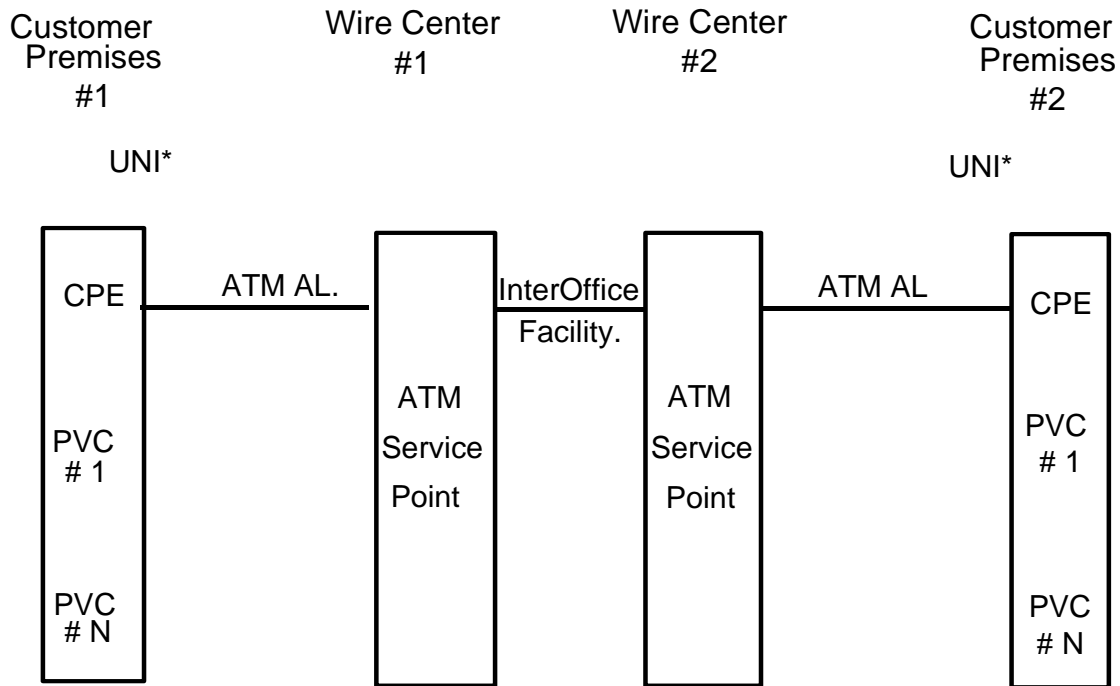

For value of N, please refer to table 2-4.

Qwest ATM Service EU customer traffic will exchange information at the UNI. This is based on the PVC signalling of UNI defined in the ATM Forum User Network Interface Specification 3.1 (1994).

**LEGEND:**  
 CPE - Customer Premise Equipment  
 ATM AL - ATM Access Link  
 UNI - User Network Interface  
 PVC - Permanent Virtual Circuit  
 VPC - Virtual Path Connection  
 VCC - Virtual Channel Connection

**Exhibit 2-2** Multiple Wire Center Configuration

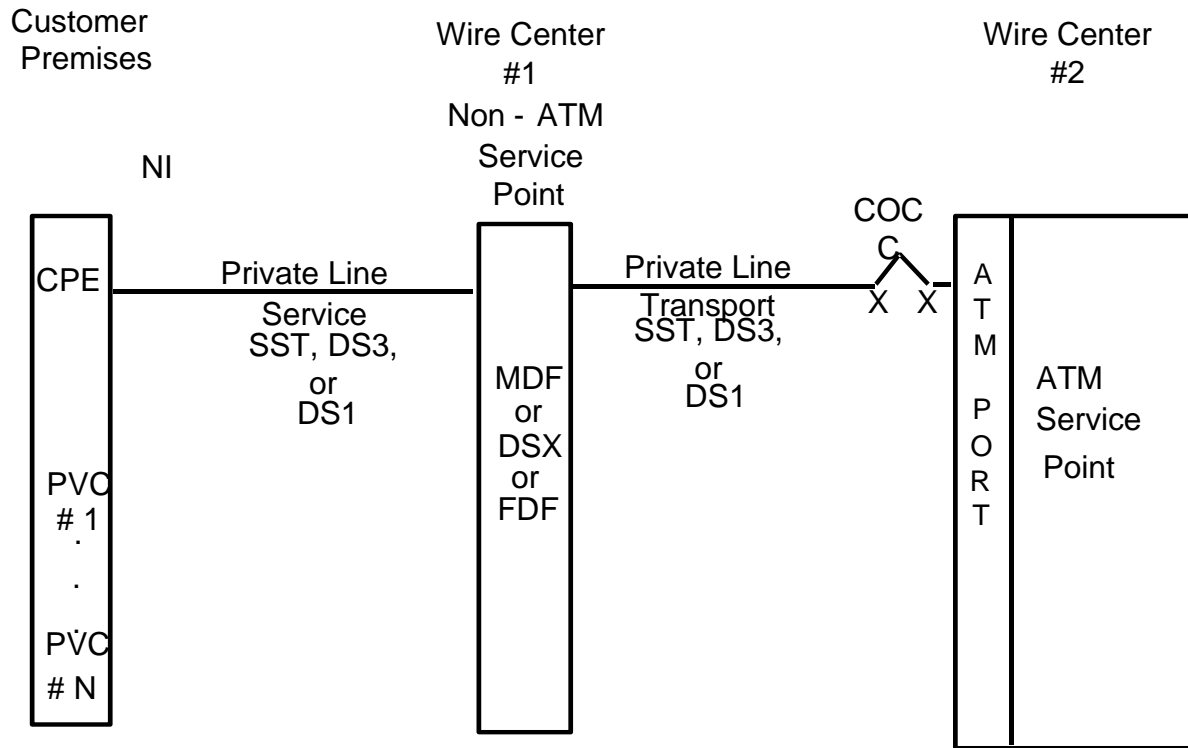

For value of N, please refer to table 2-4.

Qwest ATM Service EU customer traffic will exchange information at the UNI. This is based on the PVC signalling of UNI defined in the ATM Forum User Network Interface Specification 3.1 (1994).

**LEGEND:**  
 CPE - Customer Premise Equipment  
 ATM AL - ATM Access Link  
 UNI - User Network Interface  
 PVC - Permanent Virtual Circuit  
 VPC - Virtual Path Connection  
 VCC - Virtual Channel Connection

**Exhibit 2-3** Non-Local Qwest ATM Service Point Service Configuration  
(Private Line Service Option)

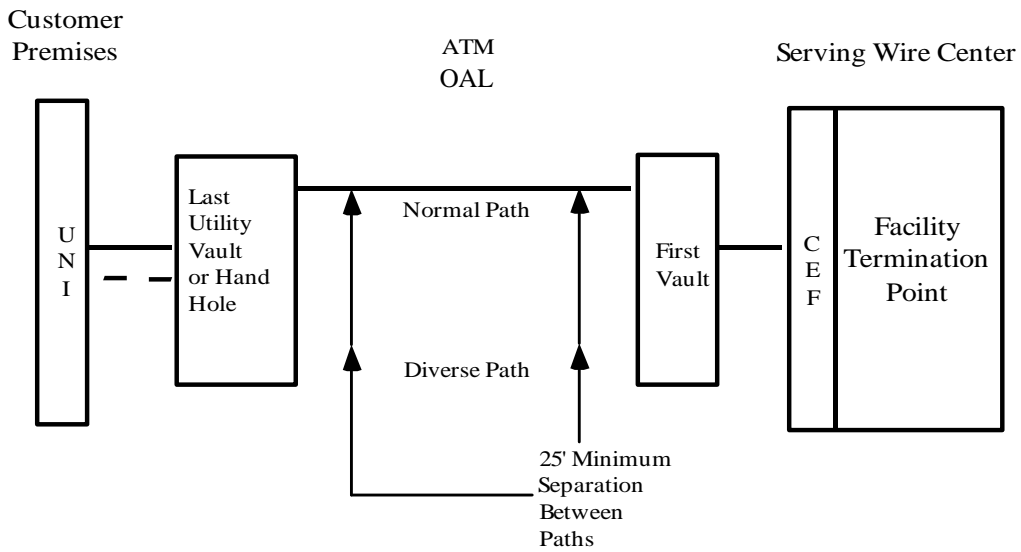

NOTE: There is no minimum separation from the vault/ terminal into the wire center/ customer premises

**LEGEND:**  
OAL - Optical Access Link  
CE F - Cable Entrance Facility  
UNI - User Network Interface

**Exhibit 2-4** Optical Access Link Diversity Service Configuration

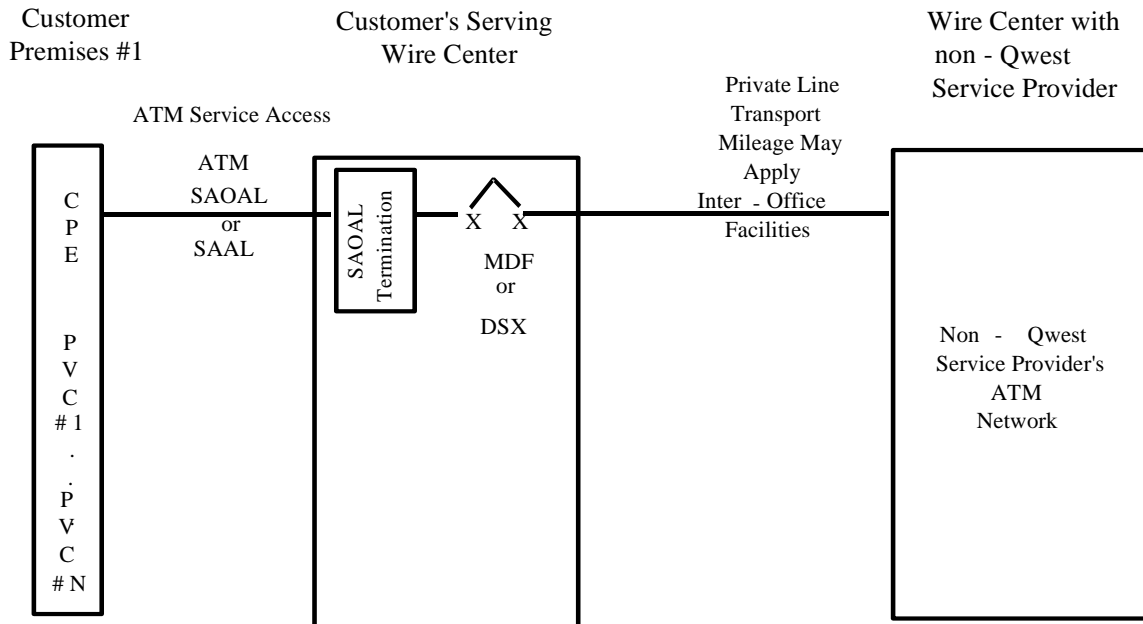

For value of N, please refer to table 2-4.

Qwest ATM Service EU customer traffic will exchange information at the UNI. This is based on the PVC signalling of UNI defined in the ATM Forum User Network Interface Specification 3.1 (1994).

LEGEND	
CPE-	Customer Provided Equipment
UNI-	User Network Interface
PVC-	Permanent Virtual Circuit
SAOAL	Stand Alone Optical Access Link
SAAL	Stand Alone Access Link

**Exhibit 2-5** Stand Alone Optical Access Link or Stand Alone Access Link Service Configuration

## CONTENTS

Chapter and Section	Page
3. Physical Layer .....	3-1
3.1 Description of Network Interfaces (NIs) for Qwest ATM Service .....	3-1
3.1.1 622.080 Mbps User Network Interface .....	3-1
3.1.2 155.520 Mbps User Network Interface .....	3-1
3.1.3 44.736 Mbps User Network Interface .....	3-1
3.1.4 1.544 Mbps User Network Interface .....	3-1
3.2 Network Interface (NI) Power Levels .....	3-2
3.3 NC and NCI Code Definitions .....	3-2
3.3.1 NC Code .....	3-2
3.3.2 NCI Code .....	3-2
3.3.3 Code Structure .....	3-2
3.3.4 Data Element .....	3-2
3.3.5 A = Alpha characters, A-Z .....	3-2
3.3.6 N = Numeric characters, 0-9 .....	3-2
3.4 Network Channel (NC) Format Structure .....	3-2
3.4.1 Channel Code .....	3-3
3.4.2 Optional Feature Code .....	3-3
3.5 NC Codes .....	3-3
3.5.1 NC Code Form .....	3-3
3.5.2 NC Code Components .....	3-4
3.5.3 Compatible NC Codes for the ATM Service 622.080 Mbps Optical Access Link .....	3-4
3.5.4 Compatible NC Codes for the ATM Service 155.520 Mbps Optical Access Link .....	3-4
3.5.5 Compatible NC Codes for the ATM Service 44.736 Mbps Optical Access Link .....	3-5
3.5.6 Compatible NC Codes for ATM Service 1.544 Mbps for IMA .....	3-5
3.6 Network Channel Interface (NCI) Format Structure .....	3-5
3.6.1 Total Conductors .....	3-6
3.6.2 Protocol .....	3-6
3.6.3 Impedance .....	3-6
3.6.4 Protocol Options .....	3-6
3.6.5 Transmission Level Points (TLPs) .....	3-7
3.6.6 The NCI Delimiter Usage .....	3-7
3.6.7 Applicable NCI Protocol Codes For ATM Service Optical Access Links .....	3-7
3.6.8 ATM Service 622.08 Mbps Optical Access Link NCI Codes at the Carrier Interface and IC-POP. ....	3-7

## CONTENTS (Continued)

Chapter and Section	Page
3.6.9 ATM Service 622.080 Mbps Optical Access Link NCI Codes at the EU-POT .....	3-7
3.6.10 ATM Service 155.520 Mbps Optical Access Link NCI Codes at the Carrier Interface and IC-POP .....	3-8
3.6.11 ATM Service 155.520 Mbps Optical Access Link NCI Codes at the EU-POT .....	3-8
3.6.12 ATM Service 44.736 Mbps Optical Access Link NCI Codes at the Carrier Interface and IC-POP .....	3-8
3.6.13 ATM Service 44.736 Mbps Optical Access Link NCI Codes at the EU-POT .....	3-8
3.6.14 Specifying NCI Codes for ATM Service Optical Access Links.....	3-8
3.6.15 Specifying NCI Codes for ATM Service Optical Access Links.....	3-9
3.7 Application of ATM Service with other Qwest Services.....	3-9
3.7.1 Qwest DS1 Service with Qwest ATM Service .....	3-9
3.7.2 Qwest DS3 Service with Qwest ATM Service .....	3-10
3.7.3 Qwest Self-Healing Alternate Route Protection with Qwest ATM Service.....	3-10
3.7.4 Qwest Self Healing Network Service with Qwest ATM Service	3-10
3.7.5 Qwest Synchronous Service Transport with Qwest ATM Service	3-11
3.8 ATM CPE Card Information.....	3-11

### Figures

3-1 Format Structure for NC Code.....	3-3
3-2 NCI Format Structure .....	3-6

### Tables

3-1 622.080 Mbps Access Compatible NC Codes.....	3-4
3-2 155.520 Mbps Access Compatible NC Codes.....	3-4
3-3 44.736 Mbps Access Compatible NC Codes.....	3-5
3-4 1.544 Mbps Access Compatible NC Codes for IMA.....	3-5
3-5 ATM Service NC/NCI Compatible Combinations.....	3-9
3-6 Compatible NC Codes for 1.544 Mbps Access.....	3-10
3-7 Compatible NC Codes for 1.544 Mbps Access for IMA.....	3-10
3-8 ATM CPE Options for 1.544 Mbps .....	3-11
3-9 ATM CPE Options for 44.736 Mbps .....	3-12
3-10 ATM CPE Options for UBR Service, all port speeds.....	3-12

**Exhibits**

3-1	155.520 Mbps Interface EU Premises.....	3-13
3-2	44.736 Mbps Interface EU Premises.....	3-14



### **3. Physical Layer**

#### **3.1 Description of Network Interfaces (NIs) for Qwest ATM Service**

##### **3.1.1 622.080 Mbps User Network Interface**

A Qwest ATM Service 622.080 Mbps Optical Access Link is provided to a customer End-User (EU). The signal characteristic at the NI of an EU customer conform to ANSI T1.105, "Telecommunications – Digital Hierarchy Optical Interface Rates and Formats Specifications (SONET)" the standard for Digital Hierarchy – Optical Interface Rates and Formats Specifications (SONET). The optical characteristics at the UNI of an EU customer conform to GR-NWT-000253, "Synchronous Optical Network (SONET) Transport Systems: Common Generic Criteria.

The physical NI to an EU customer will be a fiber optic connector of type FC-PC. The FC-PC type connector is a 2.5 mm ferrule, keyed bayonet format connector. Wiring and application information for the FC-PC connector is shown in Exhibit 3-1.

##### **3.1.2 155.520 Mbps User Network Interface**

A Qwest ATM Service 155.520 Mbps Optical Access Link is provided to a customer End-User (EU). The signal characteristics at the NI of an EU customer conform to ANSI T1.105, "Telecommunications - Digital Hierarchy Optical Interface Rates and Formats Specifications (SONET)" the standard for Digital Hierarchy - Optical Interface Rates and Formats Specifications (SONET). The optical characteristics at the UNI of an EU customer conform to GR-NWT-000253, "Synchronous Optical Network (SONET) Transport Systems: Common Generic Criteria.

The physical NI to an EU customer will be a fiber optic connector of type FC-PC. The FC-PC type connector is a 2.5 mm ferrule, keyed bayonet format connector. Wiring and application information for the FC-PC connector is shown in Exhibit 3-1.

##### **3.1.3 44.736 Mbps User Network Interface**

A Qwest ATM Service 44.736 Mbps Optical Access Link is provided to a customer EU. The signal characteristics at the NI of an EU customer are described in ANSI T1.404, "Telecommunications - Carrier-to-Customer Installation - DS3 Metallic Interface Specifications".

The physical NI to an EU customer will be a connector of type SJA44. Wiring and application information for the SJA44 jack is shown in Exhibit 3-2.

##### **3.1.4 1.544 Mbps User Network Interface**

The Qwest ATM Service 1.544 Mbps service offering is provided to a customer EU via Qwest DS1 Service (see Section 3.8.1). The signal characteristics at the NI of an EU customer are described Qwest Technical Publication 77375.

The physical NI to an EU customer will be a Registration Jack of type: RJ48C, RJ48H, RJ48M. The selection of one of the above physical connectors is a customer option.

### 3.2 Network Interface (NI) Power Levels

It is the responsibility of the transmitting party to achieve the minimum interface power. The optical power level at the 622.080 Mbps and 155.520 Mbps interface should meet the following minimum fixed power point levels:

- **Intermediate reach laser (1310 nm)**

The EU customer will receive not less than - 28 dB at the NI.

The EU customer will transmit not less than -15 dB at the NI.

- **Long reach laser (1310 nm)**

The EU customer will receive not less than -34 dB at the NI.

The EU customer will transmit not less than -5 dB at the NI.

These levels were developed to allow for maximum distances between the EU customer and the ATM Service Point. It is the responsibility of the receiving party to attenuate the optical signal level if required.

### 3.3 NC and NCI Code Definitions

#### 3.3.1 NC Code

The NC code is an encoded representation used to identify both switched and non-switched services. Included in this code set are customer options associated with individual channel services, or feature groups and other switched services.

#### 3.3.2 NCI Code

The NCI code is an encoded representation used to identify five (5) interface elements located at a Point of Termination (POT) in either a Central Office (CO) or a customer location. The interface elements include Total Conductors, Protocol, Impedance, Protocol Options and Transmission Level Points (TLP).

#### 3.3.3 Code Structure

The basic structure characteristics of NC/NCI codes; lengths and generic representation.

#### 3.3.4 Data Element

A uniquely named and defined category of data (e.g., Protocol Format Structure), a combination of data elements grouped in a prescribed sequence.

#### 3.3.5 A = Alpha characters, A-Z

#### 3.3.6 N = Numeric characters, 0-9

### 3.4 Network Channel (NC) Format Structure

An NC code is a four-character code with two data elements: Channel Code and Optional Feature Code. The format is illustrated in Figure 3-1.

Network Channel Code				
Data Element	Channel Code		Optional Feature Code	
Character Position	1	2	3	4
Character Key	X	X	X or -	X or -

X = Alphanumeric  
 - = Hyphen

**Figure 3-1** Format Structure for NC Code

#### 3.4.1 Channel Code

The **Channel Code** (character position 1 and 2) is a two character alpha or alphanumeric code that describes the channel service in an abbreviated form. The channel code will frequently, but not always, be specified as the service code of the special service circuits or the transmission grade of the message trunk circuit. The NC channel code field is always filled.

#### 3.4.2 Optional Feature Code

The **Optional Feature** (character position 3 and 4) is a two character alpha or alphanumeric or hyphen code that represents the option codes available for each channel code. Varying combinations of this code will allow the customer to enhance the technical performance of the requested channel, or to further identify the type of service. It is also used to specify options such as conditioning, effective 4-wire, multiplexing, etc. The NC Optional Code field is always filled.

### 3.5 NC Codes

The NC Code is an encoded description of the channel provided by Qwest. This channel is established between one of the following:

- Carrier, Interexchange Carrier (IXC) or Qwest Point of Termination (POT) and an EU-POT.
- Two EU-POTs
- Two Carrier POTs

The NC Code set contains customer options associated with individual channel services. The EU customer or Carrier must specify the NC codes for the desired service when ordering Qwest ATM Service. This section describes the NC codes that apply specifically to Qwest ATM Service. The ATM Service NC Code definitions emulate

existing NC Code definitions, only differing by a "fast packet" identifier that signifies the transport of packets over a communications channel provided by Qwest ATM Service.

### 3.5.1 NC Code Form

The NC code has the form XGBB. There are always four positions. There are neither spaces nor delimiters between the characters.

### 3.5.2 NC Code Components

An NC code consists of four alpha/numeric characters. The first two positions are the alpha Channel Codes used to define the basic channel type. The latter two positions are used to identify the channel options. The options positions may take the value of a dash ( - ).

### 3.5.3 Compatible NC Codes for the ATM Service 622.080 Mbps Optical Access Link

Table 3-1 lists the compatible STS12c, OC-12 NC codes for the 622.080 Mbps ATM Service Optical Access Link and Stand Alone Optical Access Link associated with Qwest ATM Service. The NC Codes listed in Table 3-1 are applicable for access service applications of Qwest ATM Service.

**Table 3-1 622.080 Mbps Access Compatible NC Codes**

Network Channel Code	Description
OD-P	OC12 SONET, None / Point to Point, Optical termination on a switch (e.g., ATM)
ODAP	OC12 SONET, Loop Timing / Point to Point, Optical termination on a switch (e.g., ATM)
ODBP	OC12 SONET, External Timing / Point to Point, Optical termination on a switch (e.g., ATM)

### 3.5.4 Compatible NC Codes for the ATM Service 155.520 Mbps Optical Access Link

Table 3-1 lists the compatible STS3c, OC-3 NC codes for the 155.520 Mbps ATM Service Optical Access Link and Stand Alone Optical Access Link associated with Qwest ATM Service. The NC Codes listed in Table 3-2 are applicable for access service applications of Qwest ATM Service.

**Note:** OBBP should only be used for a 155.520 Mbps SAOAL. OBAP is the preferred NC code for a 155.520 Mbps OAL.

**Table 3-2** 155.520 Mbps Access Compatible NC Codes

Network Channel Code	Description
OB-P	OC-3 SONET, None / Point to Point, Optical termination on a switch (e.g., ATM)
OBAP	OC-3 SONET, Loop Timing / Point to Point, Optical termination on a switch (e.g., ATM)
OBBP	OC-3 SONET, External Timing / Point to Point, Optical termination on a switch (e.g., ATM)

### 3.5.5 Compatible NC Codes for the ATM Service 44.736 Mbps Optical Access Link

Table 3-2 lists the compatible NC codes for the 44.736 Mbps ATM Service Optical Access Link and Stand Alone Optical Access Link associated with Qwest ATM Service. The NC Codes listed in Table 3-3 are applicable for access service applications of Qwest ATM Service.

**Table 3-3** 44.736 Mbps Access Compatible NC Codes

Network Channel Code	Description
HFCA	High Capacity Channel Service HC3, C-Bit Parity M Framed, PLCP Mapped ATM Cells
HFCB	High Capacity Channel Service HC3, C Bit Parity M Framed, Direct Mapped ATM

### 3.5.6 Compatible NC Codes for the ATM Service 1.544 Mbps IMA

Table 3-4 lists the compatible NC codes for the 1.544 Mbps ATM Service Access Link associated with Qwest Inverse Multiplexing over ATM (IMA) Service.

**Table 3-4** 1.544 Mbps Access Compatible NC Codes for IMA

Network Channel Code	Description
YHUA	NxDS1. Where "N" is equivalent to 2 Channels.
YHUB	NxDS1. Where "N" is equivalent to 3 Channels.
YHUC	NxDS1. Where "N" is equivalent to 4 Channels.
YHUD	NxDS1. Where "N" is equivalent to 5 Channels.
YHUE	NxDS1. Where "N" is equivalent to 6 Channels.
YHUF	NxDS1. Where "N" is equivalent to 7 Channels.

YHUG	NxDS1. Where "N" is equivalent to 8 Channels.
------	-----------------------------------------------

### 3.6 Network Channel Interface (NCI) Format Structure

This section provides a brief description of the NCI format. The NCI code format contains a maximum of twelve characters that identify five (5) data elements (see Figure 3-2). A complete description of the NCI codes can be found in ANSI T1.223, "Telecommunications-Information Interchange - Structure and Representation of Network Channel (NC) and Network Channel Interface (NCI) Codes for the North American Telecommunications System." The NCI code identifies characteristics of the NI at the customers Point of Termination (POT).

The interface to the Qwest Network is described by an interface code for each EU customer or carrier termination. The customer must specify the interface code when ordering the desired service. An ATM Service NCI code has four components as illustrated in Figure 3-1. The components of the NCI code format are illustrated in Figure 3-2, and are described below:

**Network Channel Interface Code**

Total Conductors		Protocol		I m p e d a n c e	D e l i m i t e r	Protocol Options			D e l i m i t e r	TLP Level	
										T r a n s m i t	R e c e i v e
1	2	3	4	5	6	7	8	9	10	11	12
N	N	A	A	X	•	X	X	X	•	X or -	X or -

A = Alpha  
 N = Numeric  
 X = Alphanumeric  
 • = Delimiter (normally a period)  
 - = Hyphen

**Figure 3-2** NCI Format Structure

#### 3.6.1 Total Conductors

Total Conductors (character positions 1 and 2) is a two-character numeric code that represents the total number of physical conductors; e.g., wires, required at the interface. This field is always populated.

#### 3.6.2 Protocol

Protocol (character positions 3 and 4) is a two-character alpha code that defines requirements for the interface regarding signaling and transmission. This field is always populated.

### **3.6.3 Impedance**

Impedance (character position 5) is a one-character alpha or numeric code representing the nominal reference impedance that will terminate the channel for the purpose of evaluating transmission performance. This field is always populated.

### **3.6.4 Protocol Options**

Protocol Options (character positions 7, 8, and 9) is a one to three character alpha, numeric, or alpha-numeric code that describes additional features; e.g., bit rate, bandwidth, etc., on the Protocol to be used. It is an optional field that is always left-justified when less than three characters are specified.

### **3.6.5 Transmission Level Points (TLPs)**

TLPs do not apply for Qwest ATM Service.

### **3.6.6 The NCI Delimiter Usage**

Delimiters are required for overall code readability when using the NCI code format in a manual or mechanized mode. For purposes of this document and to be consistent with most service order and mechanized systems, delimiters will be counted as characters of information. The actual character used as the delimiter may differ from system to system, but is generally either a period ( . ) or a virgule ( \ , / ). Delimiter representation for the NCI code may not be specified as alpha, numeric, or hyphen.

The NCI code delimiters will be labeled as Delimiter #1 and #2 to show the difference between the delimiters (see Figure 3-2).

Delimiter #1 is used to indicate the start of the Protocol Option field if a Protocol Option code is assigned. When specified it will be in character position six (6).

Delimiter #2 is used to indicate the start of the TLP field if a TLP level is assigned to TRSG or RCVG or both. Delimiter #2 will not be assigned if both the TRSG and RCVG TLP character positions are blank.

If the Protocol Option Field is not coded and the TLP is coded, a double Delimiter #1 and #2 will be placed after character position five (5). In this case Delimiter #1 will be in character position six (6), and Delimiter #2 will be in character position seven (7). The TLP will be left justified into character positions eight (8) and nine (9) accordingly.

If the Protocol Option Field is assigned, the Delimiter #2 character position will be dependent on the length of the Protocol Option code. Delimiter #2 is used in character position ten (10) if a three character Protocol Option code is assigned. Delimiter #2 will be in character position nine (9) if a two character Protocol Option code is assigned. Delimiter #2 will be in character position eight (8) if a one character Protocol Option code is assigned.

### **3.6.7 Applicable NCI Protocol Codes For ATM Service Optical Access Links**

Existing NCI Codes for 1.544 Mbps, 44.736 Mbps, 155.520 Mbps and 622.08 Mbps NIs apply for Qwest ATM Service. ATM Service uses all the existing NCI specifications to define the EU customer network access.

### **3.6.8 ATM Service 622.08 Mbps Optical Access Link NCI Codes at the Carrier Interface and IC-POP.**

These NCI Codes will be identified in a future issue of this publication, when Qwest offers inter-Local Access Transport Area (inter-LATA) ATM Service.

### **3.6.9 ATM Service 622.080 Mbps Optical Access Link NCI Codes at the EU-POT**

The SO protocol code is used to specify the interface at the EU-POT. The ATM Service 622.08 Mbps unprotected Optical Access Link NCI Codes with a SO protocol code may take the following forms:

- 02SOF.D equals IR1-SLM (Intermediate Reach - Single-Longitudinal Mode)
- 02SOF.B equals LR1-SLM (Long Reach - Single-Longitudinal Mode)
- 

### **3.6.10 ATM Service 155.520 Mbps Optical Access Link NCI Codes at the Carrier Interface and IC-POP**

These NCI Codes will be identified in a future issue of this publication, when Qwest offers inter-Local Access Transport Area (inter-LATA) ATM Service.

### **3.6.11 ATM Service 155.520 Mbps Optical Access Link NCI Codes at the EU-POT**

The SO protocol code is used to specify the interface at the EU-POT. The ATM Service 155.520 Mbps unprotected Optical Access Link NCI Codes with a SO protocol code may take the following forms:

- 02SOF.D.-- equals IR1-SLM (Intermediate Reach - Single-Longitudinal Mode)
- 02SOF.B.-- equals LR1-SLM (Long Reach - Single-Longitudinal Mode)

The ATM Service 155.520 Mbps protected Optical Access Link NCI Codes with a SO protocol code may take the following forms:

- 04SOF.D.-- equals IR1-SLM (Intermediate Reach - Single-Longitudinal Mode)
- 04SOF.B.-- equals LR1-SLM (Long Reach - Single-Longitudinal Mode)

### 3.6.12 ATM Service 44.736 Mbps Optical Access Link NCI Codes at the Carrier Interface and IC-POP

These NCI Codes will be identified in a future issue of this publication, when Qwest offers Inter-LATA ATM Service.

### 3.6.13 ATM Service 44.736 Mbps Optical Access Link NCI Codes at the EU-POT

The DS protocol code is used to specify the interface at the EU-POT. The ATM Service 44.736 Mbps Optical Access Link NCI Codes with a DS protocol code may take the following form:

04DS6.44I                      44.736 Mbps Electrical Interface, C-Bit Parity

### 3.6.14 Specifying NCI Codes for ATM Service Optical Access Links

The NCI codes specified by the customer when subscribing to the Qwest ATM Service must be compatible. Section 3.6.13 provides additional NCI compatibility information based upon the NC Codes defined for the Qwest ATM Service access rates (e.g., 1.544 Mbps, 44.736 Mbps, 155.520 Mbps and 622.08 Mbps).

### 3.6.15 Specifying NCI Codes for ATM Service Optical Access Links

Table 3-5 lists the recommended NC/NCI compatible combinations for Qwest ATM Service Optical Access Links. A complete list of all NC/NCI valid combinations is beyond the scope of this publication due to the various levels of multiplexing which may be encountered when interconnecting other services with Qwest ATM Service.

**Table 3-5** ATM Service NC/NCI Compatible Combinations

NC Code	Characteristics	Compatible NCI Code
OD-P	Direct Mapped ATM Cells, Point to Point	02SOF.D, 02SOF.B 04SOF.D, 04SOF.B
ODAP	Direct Mapped ATM Cells, Loop Timing	02SOF.D, 02SOF.B 04SOF.D, 04SOF.B
ODBP	Direct Mapped ATM Cells, Loop Timing	02SOF.D, 02SOF.B 04SOF.D, 04SOF.B
OB-P	Direct Mapped ATM Cells, Point to Point	02SOF.D, 02SOF.B 04SOF.D, 04SOF.B
OBAP	Direct Mapped ATM Cells, Loop Timing	02SOF.D, 02SOF.B 04SOF.D, 04SOF.B
OBBP	Direct Mapped ATM cells, External Timing	02SOF.D, 02SOF.B 04SOF.D, 04SOF.B
HFCA	PLCP Mapped ATM Cells, C-Bit Parity	04DS6.44A
HFCB	Direct Mapped ATM Cells, C Bit Parity	04DS6.44A

### 3.7 Application of ATM Service with other Qwest Services

Interconnection to ATM Service from other Qwest Services (e.g., Qwest DS1, DS3, SHARP, SHNS, SST) is supported via a Central Office Connecting Channel arrangement. These arrangements are discussed in Subsections 3.7.1 - 3.7.5.

#### 3.7.1 Qwest DS1 Service with Qwest ATM Service

Qwest DS1 Service is described in Publication 77200 "Qwest DS1 Service and Qwest DS1 Rate Synchronization Service" as well as Publication 77375, "1.544 Mbps Channel Interfaces". These publications should be consulted for a full description of the service. Qwest Private Line Transport DS1 Service is a high capacity, high performance information channel designed for full duplex, point-to-point transmission at 1.544 Mbps. DS1 Clear Channel (DS1 CC) is required for connection to the Qwest ATM Service Network. Clear Channel Capability fully utilizes the available 1.536 Mbps of a 1.544 Mbps channel. DS1 CC operation is enabled through the use of the Bipolar Eight Zero Substitution (B8ZS) line code. The DS1 signal must use Extended Superframe Format (ESF) for connection to the Qwest ATM Service Network.

The Network Interface from the customer to the Qwest Network is provided via the DS1 Service private line tariff. A COCC is required to implement a Qwest DS1 Service connection to the Qwest ATM Service Network. In order to provide DS1 Service with ATM, DS1 Service must be available to the customer.

The NC and NCI codes that are required for use in conjunction with the Qwest DS1 Service portion of this service are listed in Table 3-6.

**Table 3-6** Compatible NC Codes for 1.544 Mbps Access

NC Code	Characteristics	Qwest CO Premises Compatible NCI Code	End User Premises Compatible NCI Code
HCEJ	ANSI ESF and B8ZS, ATM Termination	04DS9.1S	04DU9.1SN

Table 3-7 lists the compatible NCI codes for Inverse Multiplexing over ATM (IMA). The NC codes can be found in the previous Table 3-4.

**Table 3-7** Compatible NCI Codes for 1.544 Mbps Access IMA

Characteristics	Qwest CO Premises Compatible NCI Code	End User Premises Compatible NCI Code

ANSI ESF and B8ZS, ATM Termination	04CX9	04DU9.1SN
---------------------------------------	-------	-----------

### **3.7.2 Qwest DS3 Service with Qwest ATM Service**

Qwest DS3 Service is described in Technical Publication 77324, "Qwest DS3 Service". The publication should be consulted for a full description of the service. Qwest DS3 Service consists of a high capacity channel for the transmission of 44.736 Mbps isochronous serial data having a line code of Bipolar Three Zero Substitution (B3ZS).

The Network Interface from the customer to the Qwest Network is provided via the DS3 Service private line tariff. A COCC is required to implement a Qwest DS3 Service connection to the Qwest ATM Service Network. In order to provide DS3 Service with ATM, DS3 Service must be available to the customer.

### **3.7.3 Qwest Self-Healing Alternate Route Protection with Qwest ATM Service**

Qwest Self-Healing Alternate Route Protection (SHARP) Service is described in Technical Publication 77340, "Self-Healing Alternate Route Protection (SHARP)". The publication should be consulted for a full description of the service.

SHARP is an optional service that improves the reliability of DS1 or DS3 services that are transported over fiber optic facilities. This feature provides a separate facility path for the protection system between the Serving Wire Center (SWC) and the Qwest Point of Termination (POT) located in the same building as the customer designated premises.

The Network Interface from the customer to the Qwest Network is provided via the SHARP Service private line tariff. A COCC is required to implement a Qwest SHARP connection to the Qwest ATM Service Network. In order to provide SHARP with ATM, SHARP must be available to the customer.

### **3.7.4 Qwest Self Healing Network Service with Qwest ATM Service**

Qwest Self Healing Network Service (SHNS) is described in Technical Publication 77332, "Self Healing Network Service". The publication should be consulted for a full description of the service.

Qwest Self Healing Network Service offers a premium service arrangement designed to provide survivability of premises or between customer designated premises and Qwest Wire Centers. The SHNS dedicates available bandwidth on the network exclusively to a single customer.

The Network Interface from the customer to the Qwest Network is provided via the SHNS private line tariff. A COCC is required to implement a Qwest SHNS connection to the Qwest ATM Service Network. In order to provide SHNS with ATM, SHNS must be available to the customer.

### 3.7.5 Qwest Synchronous Service Transport with Qwest ATM Service

Qwest Synchronous Service Transport (SST) Service is described in Technical Publication 77346, "Synchronous Service Transport". The publication should be consulted for a full description of the service.

The Network Interface from the customer to the Qwest Network is provided via the SST Service private line tariff. A COCC is required to implement a Qwest SST connection to the Qwest ATM Service Network. In order to provide SST with ATM, SST must be available to the customer.

### 3.8 ATM CPE Card Information

Tables 3-8, 3-9, and 3-10 identify and recommend options for the customer provided ATM equipment. Note that not all customer provided ATM equipment may have the following options and/or features. However, an attempt has been made to identify and select the most common options. Often, ATM default settings will be acceptable when subscribing to Qwest ATM Service. Constant Bit Rate (CBR), Variable Bit Rate (VBR) and Available Bit Rate (ABR) settings will not be known until the time of service subscription, and should be set equal to the subscribed parameters. Since Qwest ATM Service offers optional Maximum Burst Sizes (100, or 200 cells), it is recommended that the EU customer set their CPE buffer size appropriately. This should allow for maximum data transfer rates with no cell loss.

**Table 3-8** ATM CPE Options for 1.544 Mbps

Basic Features / Options	Setting
Loop Timing	Enabled
Internal Timing	Disabled
Buffer Size	Dependent on Service Option
DS1 Frame Format	Extended Super Frame
DS1 Cell Mapping (customer option)	Direct Map (HEC)
DS1 Line Coding	B8ZS
ESF Performance Report Messages	ON
Cell Scrambling	OFF

**Table 3-9** ATM CPE Options for 44.736 Mbps

Basic Features / Options	Setting
Loop Timing	Enabled
Internal Timing	Disabled
Buffer Size	Dependent on Service Option
DS3 Frame Format	C Bit Parity
DS3 Cell Mapping (customer option)	PLCP or Direct Map
Cell Scrambling	OFF

**Table 3-10** ATM CPE Options for UBR Service, all port speeds

Basic Features / Options	Setting
Early Packet Discard (EPD)	ON
Minimum Cell Rate (MCR)	zero (0)
Peak Cell Rate (PCR) shaping	ON
PCR Oversubscription	yes - any (customer decision)

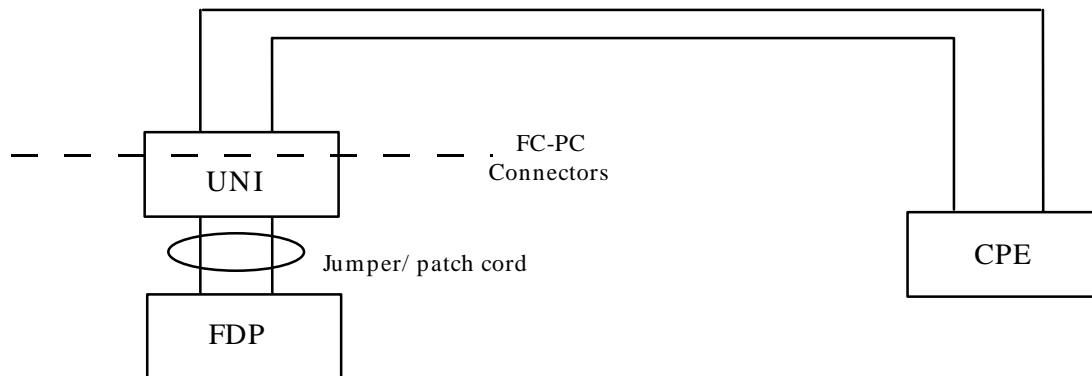

**LEGEND**  
 FDP - Fiber Distribution Panel  
 UNI - User-Network Interface  
 CPE - Customer Premises Equipment

**Exhibit 3-1** 155.520 Mbps Interface EU Premises

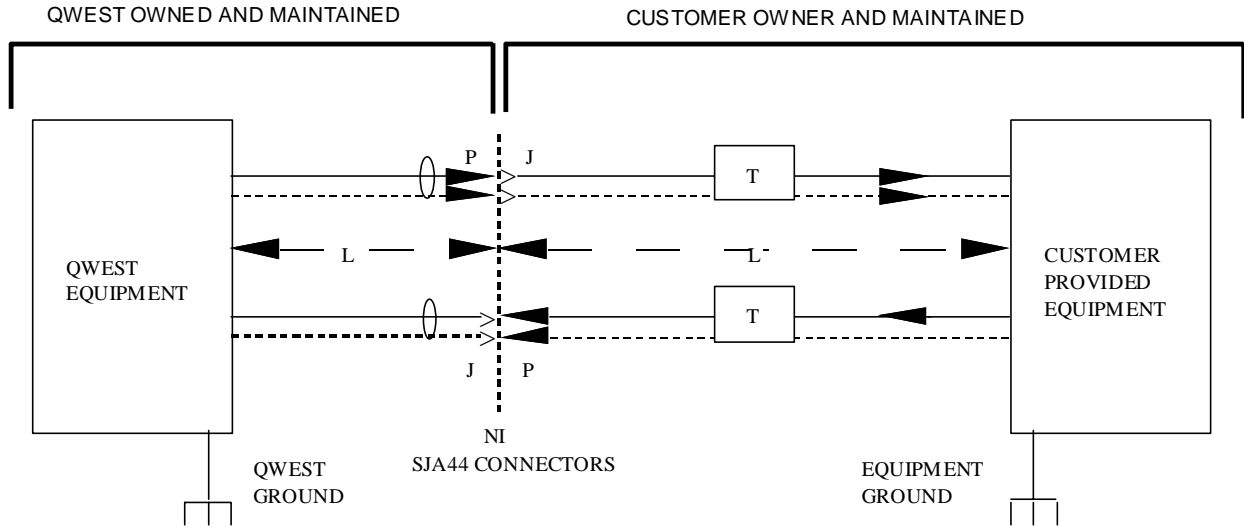

**LEGEND:**

- T - Optional wideband transformers to mitigate ground currents.
- P - TNC or BNC connector plug (see ANSI T1.404-1994, Section 8.2).
- J - TNC or BNC connector jack (see ANSI T1.404-1994, Section 8.2).
- L - Maximum distance, L = 450 feet of coaxial cable.

**Notes:**

1. This diagram indicates signal continuity arrangements and maximum allowable cable lengths. See ANSI Document ANSI T1.404-1994, Section 5 for electrical signal parameters.
2. Equipment grounding should follow recommended carrier/customer installation practices consistent with existing safety standards.
3. The BNC will be identified as the primary connector in the upcoming issue of ANSI T1.404.

**Exhibit 3-2** 44.736 Mbps Interface EU Premises

## CONTENTS

<b>Chapter and Section</b>	<b>Page</b>
4. ATM Layer Interface.....	4-1
4.1 General.....	4-1
4.2 Protocol Structure.....	4-1
4.3 Cell Structure .....	4-1
4.3.1 Generic Flow Control (GFC).....	4-2
4.3.2 Virtual Path Identifier (VPI) .....	4-2
4.3.3 Virtual Channel Identifier (VCI) .....	4-3
4.3.4 Payload Type Identifier (PTI).....	4-3
4.3.5 Cell Loss Priority (CLP).....	4-3
4.3.6 Header Error Control (HEC) .....	4-3
4.4 Cell Rate Decoupling.....	4-3

### Figures

4-1 ATM Cell Format.....	4-1
--------------------------	-----

### Tables

4-1 Preassigned or Reserved Header Values.....	4-2
4-2 PTI Code Points .....	4-3



## 4. ATM Layer Interface

### 4.1 General

The purpose of this section is to describe the cell structure and the embedded information of the cell relay ATM layer protocol. The material provided in this section represents an overview of the ATM layer protocol. More detailed information can be reviewed in the ATM Forum User Network Interface 3.1.

### 4.2 Protocol Structure

ITU-T Recommendation I.150, *B-ISDN Asynchronous Transfer Mode Functional Characteristics*, describes the functional characteristics of the ATM layer. ITU-T Recommendation I.361, *B-ISDN ATM Layer Specifications*, provides the ATM layer specifications.

### 4.3 Cell Structure

The ATM cell layer specifies the format of a 53-byte ATM cell. The ATM cell consists of a five- (5) byte header and a forty-eight - (48) byte information field. Figure 4-1 is a diagram of the basic cell format for the User Network Interface (UNI). Table 4-1 provides information regarding pre-assigned or reserved header values.

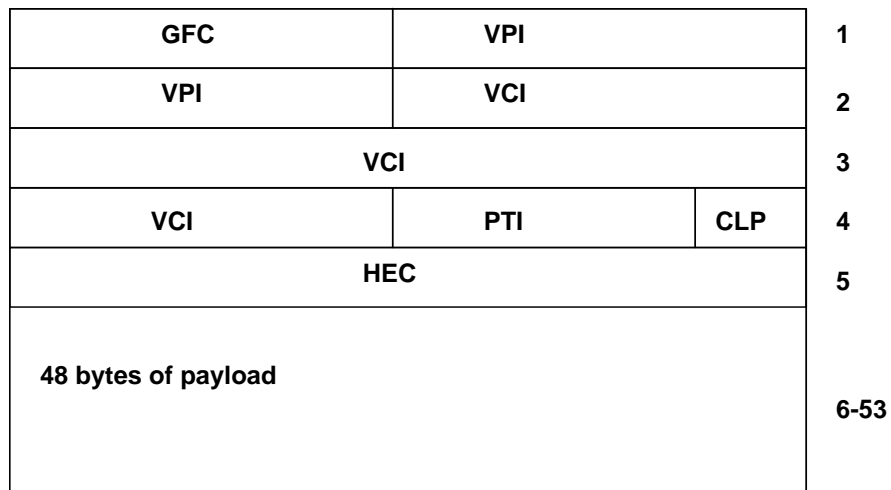

**Figure 4-1** ATM Cell Format

**Table 4-1** Pre-assigned or Reserved Header Values

Usage	VPI	VCI	PTI	CLP
Unassigned Cell	00000000	00000000 00000000	XXX	0
Idle Cell	00000000	00000000 00000000	000	1
Reserved for Physical Layer	00000000	00000000 00000000	PPP	1
Meta-signaling	XXXXXXXX	00000000 00000001	0A0	C
General Broadcast Signaling	XXXXXXXX	00000000 00000010	0AA	C
Point-to-Point Signaling	XXXXXXXX	00000000 00000101	0AA	C
Segment OAM F4 Flow Cell	YYYYYYYY	00000000 00000011	0A0	A
End-to-End OAM F4 Flow Cell	YYYYYYYY	00000000 00000100	0A0	A
Segment OAM F5 Flow Cell	YYYYYYYY	<i>ZZZZZZZZ ZZZZZZZZ</i>	100	A
End-to-End OAM F5 Flow Cell	YYYYYYYY	<i>ZZZZZZZZ ZZZZZZZZ</i>	101	A
Resource Management Cell	YYYYYYYY	<i>ZZZZZZZZ ZZZZZZZZ</i>	110	A

X= Doesn't Matter

Y = Any VPI value

Z = Any non-zero VCI

A = Use by appropriate function

C = Originator set CLP

P = Reserved for Physical Layer

### 4.3.1 Generic Flow Control (GFC)

Generic Flow Control is a four- (4) bit field reserved for flow control of a cell stream from an ATM connection at the UNI. It will be used locally to control access at the ATM level. The GFC may be used to alleviate short-term overload conditions that may occur in the customer's network (it is not used inside the Qwest ATM Service Network). The GFC will support both point-to-point and point-to-multipoint topologies. It should be noted that the exact GFC procedure has not been defined. Therefore, the only currently allowed coding for the GFC is 0000.

### 4.3.2 Virtual Path Identifier (VPI)

The VPI is an eight- (8) bit field used for routing. The VPI labels the path or trunk number for a given ATM cell. There may be multiple connections across a single physical path. A VPI identifies/labels a group of channels (VCIs) between two points. A VPI may be used to "trunk together" related VCIs. All eight bits may not be required. Those that are used are referred to as allocated bits. All unused bits are set to 0. An all zeroes pattern indicates a physical layer cell or unassigned cell.

### 4.3.3 Virtual Channel Identifier (VCI)

The VCI is a sixteen- (16) bit field used for routing. The VCI labels the individual channel or line number for a given ATM cell. A VCI identifies/labels an individual connection between two ATM end points. This identifier has only local significance and the connection it labels may be only a piece of a complete virtual circuit. Along with the VPI, the VCI values contained in the cell header are used to uniquely identify individual ATM connections. All sixteen bits may not be required. Those that are used are referred to as allocated bits. All unused bits are set to 0. An all zeroes pattern indicates a physical layer cell or unassigned cell.

### 4.3.4 Payload Type Identifier (PTI)

The Payload Type Identifier (PTI) is a three- (3) bit field reserved to indicate whether the cell contains user data or various types of network management data.

**Table 4-2** PTI Code Points

PTI Code Point (binary)	Explanation
000	User Data - SDU Type 0, no congestion experienced
001	User Data - SDU Type 1, no congestion experienced
010	User Data - SDU Type 0, congestion experienced
011	User Data - SDU Type 1, congestion experienced
100	Network management data
101	Network management data
110	Future network management data
111	Reserved for future

### 4.3.5 Cell Loss Priority (CLP)

The Cell Loss Priority (CLP) is a one (1) bit field that, when set, indicates that this cell may be discarded if conditions (e.g. switch congestion) require.

### 4.3.6 Header Error Control (HEC)

The Header Error Control (HEC) is an eight- (8) bit field where a Cyclic Redundancy Check is computed over the five-byte header to maintain the integrity of the data in the header. The integrity of data in the payload is left to a higher level protocol (e.g., TCP/IP) to ensure.

## 4.4 Cell Rate Decoupling

Unassigned cells must be added to the transmitted cell stream by the sending ATM entity. The reason for this is that a continuous cell stream matching the line rate of the UNI must be provided to the Physical Layer so that adequate cell delineation may be performed. An unassigned cell is an empty cell formatted according to the ATM Forum UNI 3.1.

## CONTENTS

<b>Chapter and Section</b>	<b>Page</b>
5. Permanent Virtual Connection (PVC) Management.....	5-1
5.1 General.....	5-1
5.2 PVC Management Procedures .....	5-1
5.2.1 PVC Management Procedures at the UNI.....	5-1
5.3 Connection Admission Control (CAC) .....	5-1
5.4 Types of PVC Management Flows.....	5-2
5.4.1 Physical Layer OAM Information Flows.....	5-2
5.4.2 ATM Layer OAM Information Flows .....	5-3
5.5 ATM PVC Administration.....	5-4

### Tables

5-1 OAM Information Flows.....	5-2
5-2 Physical Layer OAM Functions .....	5-3
5-3 ATM Layer OAM Functions.....	5-3



## **5. Permanent Virtual Connection (PVC) Management**

### **5.1 General**

Qwest ATM PVC Management Procedures will be evolving as the technology matures. The following sections describe PVC management procedures that may be utilized with Qwest ATM Service deployment.

### **5.2 PVC Management Procedures**

Qwest ATM Service PVC Management Procedures are based on the following standards and specifications:

- ATM Forum, *ATM User Network Interface Specification*, Version 3.1, Prentice-Hall 1994.
- GR-1110-CORE, *Broadband Switching System (BSS) Generic Requirements*.
- GR-1248-CORE, Generic Requirements for Operations of ATM Network Element.
- TR-NWT-001112, *Broadband ISDN User to Network Interface and Network Node Interface Physical Layer Generic Criteria*.

The Qwest ATM nodes implement PVC Management Procedures based on the above standards in order to support the functions stated below:

- VPC/VCC Monitoring
- VPC/VCC Administration
- Fault Management

#### **5.2.1 PVC Management Procedures at the UNI**

The User-Network Management Procedures implemented by the Qwest ATM Service network at the User-Network Interface (UNI) are based on the principles set forth in ITU-T Recommendation I.610, *B-ISDN Operation and Maintenance Principles and Functions*, and further described in the ATM Forum document, *User-Network Interface 3.1*.

### **5.3 Connection Admission Control (CAC)**

Connection Admission Control (CAC) is defined as the set of administrative procedures and actions taken by the Qwest ATM Service network to determine whether a request to establish a new ATM Service connection will be accepted or rejected. For example, a reason for rejecting a new ATM Service connection would be that its acceptance could result in the violation of Quality of Service (QoS) performance objectives either on this new connection or on other, already established connections. CAC functions apply to all ATM Service connections.

The CAC function uses the requested PCR, SCR and MCR values, the QoS Class and Cell Delay Variation Tolerance ( $CDV_{TOL}$ ) together with known states of the Qwest ATM network and the attached Optical Access Links to estimate whether or not the requested ATM connection can be accepted.

The CAC function allows for a statistical multiplexing efficiency that is superior to peak rate allocation when operating on ATM Service connections having appropriate traffic characteristics.

#### 5.4 Types of PVC Management Flows

The Qwest ATM Service network performs only ATM layer and physical layer Operation, Administration and Maintenance (OAM) functions. The End-User (EU) customer's communication equipment is responsible for performing ATM Adaptation Layer (AAL) and higher layer OAM functions. Protocols running above the ATM layer (i.e., the cell payload) are passed transparently through the Qwest ATM Service network. OAM functions of the physical layer and the ATM layer are structured according to OAM information flows. These information flows are described in Table 5-1.

**Table 5-1** OAM Information Flows

Flow	Description	Layer
F1	Regenerator Section	Physical Layer (SONET)
F2	Digital Section	Physical Layer (SONET)
F3	Transmission Path	Physical Layer (SONET)
F4	Virtual Path	ATM Layer
F5	Virtual Channel	ATM Layer

##### 5.4.1 Physical Layer OAM Information Flows

Physical layer (SONET) OAM functions can be divided into the following two types:

- Those dedicated to performance monitoring and reporting. This use of the F1, F2, and F3 flows is for OAM physical layer (SONET) management.
- Those dedicated to the detection and indication of unavailability states. This use of the F1, F2, and F3 flows is required for real-time failure information transfer towards the affected points within the network.

The Qwest ATM network may utilize the F1 and F3 flows as illustrated in Table 5-2.

**Table 5-2** Physical Layer OAM Functions

Flow	Function	Indicator
F1	Signal detection, cell recognition	Loss of signal
F1	Section error monitoring and reporting	Degraded or unacceptable error performance
F3	Cell rate decoupling	Failure of insertion
F3	Physical layer cell recognition	Loss of F3 cell recognition
F3	Cell delineation	Loss of cell synchronization
F3	Path error monitoring and reporting	Degraded error performance

#### 5.4.2 ATM Layer OAM Information Flows

The Qwest ATM network may utilize ATM layer OAM functions to monitor Virtual Path Connection/Virtual Channel Connection (VPC/VCC) availability and/or perform Virtual Path and Virtual Channel level performance monitoring. The ATM layer OAM functions are described in Table 5-3.

**Table 5-3** ATM Layer OAM Functions

Flow	Function	Indicator
F4	Monitoring path availability	Path not available
F4	Performance monitoring	Degraded performance
F5	Monitoring channel availability	Channel not available
F5	Performance monitoring	Degraded performance

## **5.5 ATM PVC Administration**

Each Qwest ATM node is responsible for the administration of its own ATM Network PVCs, and those of adjacent nodes. Each PVC is assigned an associated VPI/VCI for each end of a point-to-point logical connection at the time the customer subscribes to Qwest ATM Service. During the service subscription process, the assignment(s) of VPI/VCI values at the UNI will require close coordination and cooperation to achieve conformity of VPI/VCI assignments. The VPI/VCI values at each end point of the ATM Service subscriber's PVC(s) may have different values, as the VPI/VCI values are of local significance only.

PVCs will remain in the Qwest ATM node(s) until each are individually removed, even in the case of a temporary unavailability of the virtual circuits due to a service failure.

It is the responsibility of each Qwest ATM Service customer to populate and maintain its own CPE VPI/VCI routing tables. Qwest will provide end point VPI/VCI information for each PVC at service subscription time. Qwest will attempt to accommodate requests for specific VPI/VCI values at the end points whenever possible.

## CONTENTS

<b>Chapter and Section</b>	<b>Page</b>
6. Network Traffic Control and Congestion Management Responsibilities and Procedures.....	6-1
6.1 General.....	6-1
6.1.1 Purpose for Qwest ATM Service Network Traffic Control and Congestion Management Procedures .....	6-1
6.2 Network Traffic Control.....	6-1
6.2.1 Qwest ATM Service Network Traffic Control Procedures for CBR.....	6-2
6.2.2 Network Traffic Control Responsibilities for CBR.....	6-3
6.2.3 Qwest ATM Service Network Traffic Control Procedures for VBR.....	6-3
6.2.4 Network Traffic Control Responsibilities for VBR.....	6-3
6.2.5 Qwest ATM Service Network Traffic Control Procedures for UBR.....	6-3
6.3 Network Congestion Management .....	6-5
6.3.1 Explicit Forward Congestion Indication (EFCI) .....	6-6



## **6. Network Traffic Control and Congestion Management Responsibilities and Procedures**

### **6.1 General**

Qwest ATM Service performs traffic control and congestion management procedures. The purpose of this information is to provide Qwest ATM Service customers with a fundamental understanding of the traffic control and congestion management procedures that pertain to Qwest ATM Service.

Qwest ATM Service traffic control procedures will be performed in order to prevent congestion in the Qwest ATM Network. Qwest ATM Service congestion management procedures will be performed in order to alleviate congestion in the Qwest ATM Network.

#### **6.1.1 Purpose for Qwest ATM Service Network Traffic Control and Congestion Management Procedures**

Qwest ATM Service Network Traffic Control and Congestion Management Procedures will be implemented with the following goals in mind:

- Provide fairness of service during congestion among the Qwest ATM Service End Users' associated ATM port, ATM Service Optical Access Links, and PVCs,
- Maximize throughput,
- Minimize loss of data,
- To relieve the congestion condition of the ATM module in a fast and effective manner.

Qwest will also provision and monitor the ATM internodal trunk thresholds in order to avoid excessive traffic congestion from occurring between ATM nodes.

### **6.2 Network Traffic Control**

Qwest ATM Service Network Traffic Control is performed via the Usage Parameter Control (UPC) function. UPC is defined as the set of actions taken by a Qwest ATM node to monitor and control traffic at a UNI in terms of the traffic offered to the network over a Qwest ATM Service Optical Access Link and/or Port. The Qwest ATM node UPC functions are consistent with the definitions provided in the ATM Forum UNI 3.1.

The UPC function monitors the traffic offered to the network on a Qwest ATM Service Optical Access Link and/or Port for conformance with the agreed upon traffic contract.

The UPC also monitors the traffic offered to the Qwest ATM Network on an ATM Service Optical Access Link and/or Port for the validity of that connection, i.e., whether a cell's Virtual Path Identifier/Virtual Channel Identifier (VPI/VCI) values are associated with a Virtual Channel Connection (VCC) or Virtual Path Connection (VPC) which is assigned and active on that UNI. The UPC function shall discard any cell that carries an unassigned or inactive value of VPI/VCI for its UNI.

The UPC also operates on network-based measurements of the source traffic parameters Peak Cell Rate (PCR), Sustained Cell Rate (SCR) and Maximum Burst Size (MBS) used in the traffic contract associated with a given point-to-point VCC or VPC at the ingress of the Qwest ATM node supporting the UNI. The Qwest ATM node's UPC function will determine which cells associated with an active and assigned VCC or VPC are conforming or non-conforming.

### **6.2.1 Qwest ATM Service Network Traffic Control Procedures for CBR**

Traffic control for Qwest ATM Constant Bit Rate Service (CBR) is based on the Peak Cell Rate (PCR). The PCR traffic parameter specifies an upper bound on the cell rate that can be submitted across a connection. The Qwest ATM node UPC function will monitor the cell stream to test conformance with the connection's PCR.

All cells found to be non-conformant with the logical connection's provisioned characteristics, e.g., any cell exceeding the PCR by more than the allowed Cell Delay Variation Tolerance ( $CDV_{TOL}$ ) will be discarded at the source UNI. GR-1110-CORE provides a detailed explanation of this function.

In theory, the PCR of a connection represents the precise rate at which cells should flow across a connection. However, in practice, the rate at which a stream of cells is transmitted across a connection may deviate from the connection's assigned PCR (i.e., a customer's CPE device may transmit cells in clusters with the cells arriving sooner than expected across the UNI). The UPC will allow a certain amount of cell clustering (i.e., cells arriving sooner than expected) on a connection before declaring cells to be non-conformant. The  $CDV_{TOL}$  parameter is used to gauge the amount of clustering permitted on a connection. This parameter will be used to specify the amount of variation from a connection's PCR that the Qwest ATM Service Network will accept before declaring clustered cells to be non-conformant at the source UNI. Qwest will manage the  $CDV_{TOL}$  setting in such a manner that the QOS will be maintained for optimal network performance in a nondiscriminatory manner.

### **6.2.2 Network Traffic Control Responsibilities for CBR**

Qwest ATM Service CBR customers must perform traffic shaping within the Customer's CPE in order to conform with the traffic parameters agreed upon in the service contract. For CBR connections, it is the responsibility of the Customer to not exceed the agreed upon PCR.

### **6.2.3 Qwest ATM Service Network Traffic Control Procedures for VBR (VBR-rt & VBR-nrt)**

Traffic control for Qwest ATM Variable Bit Rate (VBR) is based on the Peak Cell Rate (PCR), Sustained Cell Rate (SCR), and the Maximum Burst Size (MBS).

The PCR traffic parameter specifies an upper bound on the cell rate that can be submitted across a connection. The PCR for Qwest ATM Service, VBR connections, will be agreed upon in the service contract. The Qwest ATM node UPC function will monitor the cell stream to test conformance with the connection's PCR. All cells found to be non-conformant with the logical connection's provisioned PCR will be discarded at the source UNI.

The SCR defines the "average cell rate" of a connection (i.e. rate averaged over a time interval). This SCR traffic parameter will be the primary mechanism used to allocate network bandwidth capacity associated with VBR connections. The SCR of a connection represents the sustained rate at which cells can be transmitted across a VBR connection. In addition, momentary traffic bursts can be transmitted across a VBR connection at the connection's PCR. Maximum Burst Size options of 100, or 200 cells will be available for Qwest ATM Service. The UPC function will monitor and control the cell stream for conformance with the agreed upon traffic contract. The  $CDV_{TOL}$  parameter will be used to specify the amount of variation for a connections SCR that the Qwest ATM Service Network will accept before declaring clustered cells to be non-conformant at the source UNI.

### **6.2.4 Network Traffic Control Responsibilities for VBR**

Qwest ATM VBR customers must perform traffic shaping within the Customer's CPE in order to conform with the traffic parameters agreed upon in the service contract. For VBR connections, it is the responsibility of the Customer to not exceed the agreed upon SCR and PCR.

### **6.2.5 Qwest ATM Service Network Traffic Control Procedures for UBR**

Unspecified Bit Rate (UBR) is a "best effort" service designed to support a connection carrying information flowing at uneven rates. UBR does not specify traffic related service guarantees. Specifically, UBR does not include the notion of a negotiated, per connection bandwidth. Qwest makes no numerical commitments with respect to the cell loss ratio experienced by a UBR connection, or as to the cell transfer delay experienced by cells on the connection.

Traffic control for Qwest ATM UBR is based on the Peak Cell Rate (PCR). Since no numerical commitments are made on UBR connections there is no corresponding Equivalent Cell Rate (ECR) identified for network resource utilization. Unlike CBR and VBR, UBR PVCs are not considered in the summation of bandwidth over an interface. However, the UBR PVC will be taken in account when determining the maximum allowable number of PVCs across an interface. The Qwest ATM node UPC function will monitor the cell stream to test conformance with the connection's PCR. All cells found to be non-conformant with the logical connection's provisioned characteristics, e.g., any cell exceeding the PCR may be discarded at the source UNI.

### **6.3 Network Congestion Management**

Qwest ATM nodes will monitor the traffic volume of each Qwest ATM Service Optical Access Link, and compare the Permanent Virtual Connections (PVCs) associated traffic volume with the negotiated data throughput parameters. In the event an End User's PVC(s) causes a ATM module to become congested, the customers which are assigned to the congested ATM module may experience network congestion conditions.

Network congestion conditions may cause the following conditions to be experienced by an ATM Service Customer:

- Receipt of explicit network congestion notifications
- Discarding of cells
- Excessive transit delay

If network congestion should occur due to the traffic volume of any particular PVC, Qwest recommends that the customer implement its own network congestion procedures for the following reasons:

- To reduce the impact of network congestion upon the customer's application.
- To avoid the possibility that cells may be discarded by the ATM node(s).
- Implemented congestion procedures should be exercised until the network congestion situation no longer exists.

The standard ATM protocol imposes the burden upon the higher-layer protocol functionality of the applications to perform the functions of flow control and error correction that are not performed by the ATM network. The ATM protocol standards do not specify notification of errored cells. However, the typical network protocols of the application(s) do provide implicit flow control via an acknowledgment process between applications.

### **6.3.1 Explicit Forward Congestion Indication (EFCI)**

The Explicit Forward Congestion Indication (EFCI) is a congestion notification scheme that an ATM layer service user may make use of to improve the utility that can be derived from the ATM layer. Since the use of this mechanism by Customer Provided Equipment (CPE) is optional, Qwest ATM Service network equipment cannot rely on this mechanism to control congestion.

## CONTENTS

<b>Chapter and Section</b>	<b>Page</b>
7. Performance Specifications .....	7-1
7.1 General.....	7-1
7.2 Objectives.....	7-1
7.2.1 Availability.....	7-1
7.3 Performance Parameters Definitions.....	7-2
<b>Tables</b>	
7-1 Service Performance Parameters.....	7-3



## 7. Performance Specifications

### 7.1 General

This section describes the service objectives and transmission requirements for Qwest Asynchronous Transfer Mode (ATM) Service.

The Service Class (Constant Bit Rate, Variable Bit Rate, Available Bit Rate or Unspecified Bit Rate) defines the performance and service availability characteristics of a given Qwest ATM Service connection. The parameters associated with a Service Class should be measurable by both the user and network at the access point (ATM Service UNI) to the Qwest ATM Service Network. The Service Class (CBR, VBR, ABR or UBR) associated with a given ATM Service connection is indicated to the network at the time of connection establishment and will not change for the duration of that connection.

### 7.2 Objectives

#### 7.2.1 Availability

The availability objective for Qwest ATM Service is 99.967%. The availability of a service is a measure of the Scheduled Service Time that the service is usable by a customer. The availability is expressed as a percentage the service is performing in accordance with the service performance objectives over an average 12 month period. This percentage may be expressed as:

$$\text{Availability (\%)} = \frac{(\text{Scheduled Service Time} - \text{Outage Time}) \times 100}{\text{Scheduled Service Time}}$$

The Scheduled Service Time is 8,756 hours during an average 12-month period and outage time is expressed in hours.

Overall service availability is dependent on four main factors:

- The proportion of time in which the accuracy objectives are met;
- The frequency of switching equipment outages;
- The frequency of transport system outages;
- Restoral times for outages.

Scheduled Service Time is the length of time in hours that the Qwest ATM Service Network is expected to provide Qwest ATM Service. The Scheduled Service Time for Qwest ATM Service is 8,756 hours during an average 12 month period. This allows for two hours every six months for maintenance of the Nodes (i.e., installation of software upgrades).

### 7.3 Performance Parameters Definitions

The service performance parameters for Qwest ATM Service are shown in Table 7-1 and described below. Performance parameters for UBR are not specified.

- Cell Transfer Delay (CTD)

CTD is defined as the time from when the first bit of a successfully delivered cell crosses the ingress User Network Interface (UNI) to when the last bit crosses the egress UNI. The components of CTD in a Virtual Channel Connection (VCC) or Virtual Path Connection (VPC) include:

- Emission delay (e.g., at 44.736 Mbps, emission delay is approximately 10 microseconds)
- Propagation delays (approximately 2 ms per 100 fiber miles)
- Processing delays at intermediate ATM nodes (e.g., switching/multiplexing delays)
- Queuing delays at intermediate ATM nodes.

- Cell Delay Variation (CDV)

CDV is a measure of how much the cell transfer delay experienced by any cell differs from a reference value of cell transfer delay associated with a specific logical connection. Equivalently, CDV can be thought of as a measure of the variability of inter-cell arrival times. CDV is a key parameter for planning the performance of CBR applications (i.e., delay-sensitive applications). The objective for CDV is expressed in terms of a quantile of the cumulative distribution function of CDV between communicating UNIs across the ATM Service network. For CBR, VCCs and VPCs having a Cell Loss Ratio (CLR) objective of  $10^{-9}$ , the relevant level of CDV is the  $10^{-9}$  Quantile.

- Cell Loss Ratio (CLR)

CLR is defined as the ratio of the number of cells lost to the number of transmitted cells in a population of interest.

- Cell Error Ratio (CER)

An errored cell event occurs when a successfully delivered cell contains one or more bit errors in its payload.

- Cell Misinserted Rate (CMR)

A cell misinsertion event can occur when a line burst error causes multiple errors in a cell header in such a way as to 1) cause the Header Error Control (HEC) mechanism to pass the corrupted header, or 2) have the resultant corrupt VPI/VCI value be valid for some other active virtual connection. This event will be seen as a cell loss event on the VCC in which it was transmitted and as a misinserted cell event on the VCC on which it is received.

**Table 7-1** Service Performance Parameters

Performance Parameters	Constant Bit Rate	Variable Bit Rate	Unspecified Bit Rate
Cell Transfer Delay	For 99% of all cells delivered, the Cell Transfer Delay will be < 4 ms between originating and terminating UNI, plus 2 ms per 100 fiber miles between the two UNIs.	not specified	not specified
Cell Delay Variation 10 <sup>-9</sup> Quantile, 44.736 Mbps UNI	<= 2.0 ms	not specified	not specified
Cell Delay Variation 10 <sup>-9</sup> Quantile, 155.520 Mbps UNI	<= 1.0 ms	not specified	not specified
Cell Loss Ratio	<= 10 <sup>-9</sup>	<= 10 <sup>-6</sup>	not specified
Cell Error Ratio	< 10 <sup>-7</sup>		
Cell Misinserted Rate	< 10 <sup>-13</sup>		
Availability	99.967 % (average 12 months)		

**NOTE:** ms = millisecond

## CONTENTS

<b>Chapter and Section</b>	<b>Page</b>
8. Maintenance .....	8-1
8.1 Customer Responsibilities.....	8-1
8.2 Qwest Responsibilities.....	8-1



## **8. Maintenance**

### **8.1 Customer Responsibilities**

The customer is responsible for all equipment and cable beyond the User Network Interface at their location. The physical connector at the UNI will be one of the following jacks or connectors: RJ48C, RJ48H, or RJ48M for 1.544 Mbps UNI; SJA44 for a 44.736 Mbps UNI; FC-PC for a 155.520 Mbps UNI, UNI; FC-PC for a 622.080 Mbps UNI or equivalent.

In the event of service trouble, the customer or their agent is responsible for sectionalizing the trouble, and verifying that the trouble is not in the customer owned equipment or cable before calling Qwest ATM Networking Services Customer Service Center at 1-800-227-2218.

If the service trouble is isolated to the customer owned equipment or cable, the customer or their agent is responsible for clearing the trouble and restoring the service to normal operation.

In the case of degraded service (e.g., discarded cells, excessive cell transmission delay), the customer should contact the Customer Service Center at 1-800-227-2218.

Joint testing between the customer and/or their agent, and Qwest personnel may sometimes be necessary to isolate the trouble.

### **8.2 Qwest Responsibilities**

Qwest is responsible for all equipment and cable on the Qwest side (i.e., network side) of the User Network Interface (UNI) at the customer location, and also for maintaining the transmission facility between customer locations, and between the Serving Wire Center and the customer location.

Qwest will furnish the customer a trouble reporting telephone number, and will commit to a four- (4) hour objective for service restoral in the event of a service interruption due to an electronic component failure. If the trouble is caused by a cable failure, the objective for service restore time will be eight (8) hours. The objective for service restore time in the event of a node failure is 2.5 hours.

## CONTENTS

<b>Chapter and Section</b>	<b>Page</b>
9. Definitions .....	9-1
9.1 Acronyms .....	9-1
9.2 Glossary .....	9- <del>6</del> 5



## **9. Definitions**

### **9.1 Acronyms**

AAL	ATM Adaptation Layer
ABR	Available Bit Rate
AIS	Alarm Indication Signal
ANSI	American National Standards Institute
ATM	Asynchronous Transfer Mode
B-ICI	B-ISDN Inter Carrier Interface
B-ISDN	Broadband Integrated Services Digital Network
B-ISSI	Broadband Inter-Switching System Interface
BER	Bit Error Ratio
BOC	Bell Operating Company
BSS	Broadband Switching System
BT	Burst Tolerance
BW	Bandwidth
CAC	Connection Admission Control
CBR	Constant Bit Rate
CDV	Cell Delay Variation
CDVT	Cell Delay Variation Tolerance
CER	Cell Error Ratio
CES	Circuit Emulation Service
CLP	Cell Loss Priority
CLR	Cell Loss Ratio
CMIP	Common Management Information Protocol
CMR	Cell Misinsertion Rate
CNM	Customer Network Management
CO	Central Office
COCC	Central Office Connecting Channel
CPE	Customer Premises Equipment
CPE	Customer Provided Equipment

CRC

Cyclic Redundancy Check

CRS	Cell Relay Service
CSC	Customer Service Center
CSPDN	Circuit Switched Public Data Network
CTD	Cell Transfer Delay
DSU	Data Service Unit
DSX	Digital Signal Cross-connect
DTE	Data Terminal Equipment
ECR	Equivalent Cell Rate
EFCI	Explicit Forward Congestion Indication
EICT	Expanded Interconnection and Collocation Channel Termination
EL	Element Layer
EML	Element Management Layer
EMS	Element Management System
EU	End-User
EU-POT	End-User-Point of Termination
FRS	Frame Relay Service
FTP	File Transfer Protocol
GCRA	Generic Cell Rate Algorithm
GFC	Generic Flow Control
HEC	Header Error Control
IC	Interexchange Carrier
ILMI	Integrated Local Management Interface
IMA	Inverse Multiplexing over ATM
IOF	Inter-office Facilities
IP	Internet Protocol
ITU-T	International Telecommunication Union - Telecommunications Standardization Sector
KBPS	Kilobit per second (1,000 bit/s)
LAN	Local Area Network
LATA	Local Access and Transport Area
LEC	Local Exchange Carrier

LMI	Local Management Interface
LOS	Loss of Signal
MAN	Metropolitan Area Network
MBPS	Megabit per Second (1,000,000 bit/s)
MBS	Maximum Burst Size
MCR	Minimum Cell Rate
MDF	Main Distributing Frame
MIB	Management Information Base
MS	Millisecond
MTBSO	Mean Time Between Service Outages
MTTR	Mean Time to Repair
NI	Network Interface
NM	Nanometer
NML	Network Management Layer
NMS	Network Management System
NNI	Network-Network Interface
OAM	Operations, Administration and Maintenance
PCR	Peak Cell Rate
PLCP	Physical Layer Convergence Protocol
POT	Point Of Termination
PSTN	Public Switched Telephone Network
PT-MPT	Point-to-Multipoint
PT-PT	Point-to-Point
PVC	Permanent Virtual Connection
QoS	Quality of Service
SA	Service Availability
SCR	Sustained Cell Rate
SNMP	Simple Network Management Protocol
SONET	Synchronous Optical Network
SR	Special Report
SST	Synchronous Service Transport

STM	Synchronous Transfer Mode
STS-3c	Synchronous Transport Signal level 3, concatenated
STS-12c	Synchronous Transport Signal level 12, concatenated
SVC	Switched Virtual Connection
SWC	Serving Wire Center
TC	Transmission Convergence
TCA	Threshold Crossing Alert
TCP/IP	Transmission Control Protocol/Internet Protocol
TLS	Transparent LAN Service
UBR	Unspecified Bit Rate
UNI	User Network Interface
UPC	Usage Parameter Control
VBR	Variable Bit Rate
VBR-RT	Variable Bit Rate – real time
VBR-NRT	Variable Bit Rate – non real time
VC	Virtual Channel
VCC	Virtual Channel Connection
VCI	Virtual Channel Identifier
VCL	Virtual Channel Link
VP	Virtual Path
VPC	Virtual Path Connection
VPI	Virtual Path Identifier
VPL	Virtual Path Link
WAN	Wide Area Network

## 9.2 Glossary

### **American National Standard Institute (ANSI)**

An organization supported by the telecommunications industry to establish performance and interface standards.

### **Asynchronous Transfer Mode (ATM)**

An information transfer method in which the information is organized into fixed length (53 octet) cells. It is asynchronous in the sense that the recurrence of cells containing user information is not necessarily periodic.

### **ATM Adaptation Layer (AAL)**

The protocol layer that provides service-dependent functions to the layer above the AAL and adapts various types of information streams (e.g., packets, circuits, etc.) to ATM streams.

### **ATM Cell**

A digital information block of fixed length (53 octets) identified by a label at the ATM Layer of the B-ISDN protocol architecture.

### **ATM Logical Connections**

ATM logical connections are provided as unidirectional Permanent Virtual Connections (PVCs). ATM service will support a point-to-point logical connection configuration between two ports. Logical connections may be either symmetrical or asymmetrical. A symmetrical connection is one in which the same bandwidth is specified for each direction of the connection. An asymmetrical connection has a different bandwidth value specified for each direction of the connection.

### **ATM Module**

An ATM node plug-in card that provides ATM features and functionality over any ATM ports on the card.

### **ATM Node**

An ATM switch that will be located in the Qwest Serving Wire Center and will support a capacity of 1-10 Gbps and interface counts in the range 1-282.

### **ATM Optical Access Link (OAL)**

An ATM access channel used to connect customer facilities at the Network Interface with a corresponding ATM Cell Transfer Element.

### **ATM Port**

A termination point on the ATM Module for the ATM Optical Access Link. ATM ports are the physical entry points in the ATM Network for Optical Access Links and are the originating and terminating points for Virtual Path Connections and Virtual Channel Connections.

### **ATM Service Point**

ATM Service Points are geographic locations designated by the Company where the ATM Network can be accessed.

### **Availability**

The relative amount of time that a service is "usable" by a customer; represented as a percentage over a consecutive 12 month period.

### **Bandwidth**

The frequency range of a communication signal energy or power. The range of frequencies that a communications circuit is designed to operate in.

### **Bits per second (bps)**

Bits per second, e.g., 1200 bps. In data transmission, it is the number of binary zero and one bits transmitted in 1 second.

### **Bit Error Ratio (BER)**

The ratio of the number of bit errors to the total number of bits transmitted in a given time interval.

### **Broadband Inter-Carrier Interface (B-ICI)**

An ATM-based, multi-service capable interface between two carriers that provide public ATM network service.

### **Broadband Inter-Switching System Interface (B-ISSI)**

An ATM-based interface between two BSSs within a single LEC network capable of transporting SMDS, FRS, and other ATM-based services. The B-ISSI may be operated in a single service mode, or may carry multiple services depending on the application. In special circumstances, a B-ISSI may be used to interconnect two LEC networks in a single LATA.

### **Byte**

A consecutive number of bits usually constituting a complete character or symbol. If the length of the byte is not specified, it is conventionally assumed to have a length of 8-bits. In the Digital Data System, a byte refers to an arbitrary group of 8 consecutive bits; it does not correspond to a byte of customer data.

### **Cell Delay Variation (CDV)**

A network performance parameter that characterizes the variability in cell transfer delay experienced by cells being transferred over a given ATM Layer connection.

### **Cell Rate Adapter**

A simple device that incorporates a DS3 and an OC3 interface. Cells are transferred between these two ports without inspection or alteration.

### **Central Office (CO)**

A local switching system (or a portion thereof) and its associated equipment located at a wire center.

### **Central Office Connecting Channel (COCC)**

A tariff rate category which provides for connections, within the same Hub wire center, between the Private Line Transport Channel and other services provided by Qwest. See FCC #1 for more information. **Character**

Letter, numeral, punctuation, control figure or any other symbol contained in a message.

### **Constant Bit Rate (CBR)**

An ATM Forum service category which supports a constant or guaranteed rate to transport services such as video or voice as well as circuit emulation which requires rigorous timing control and performance parameters.

### **Customers**

Denotes any individual, partnership or corporation who subscribes to the services provided by Qwest customers are divided into two distinct and separate categories: (1) carriers, who provide interexchange services for hire for others, and (2) end-users, who request services only for their own use.

### **Customer Premises**

Denotes a building or portion(s) of a building occupied by a single customer or end-user either as a place of business or residence. Adjacent buildings and the buildings on the same continuous property occupied by the customer and not separated by a public thoroughfare are also considered the customer's premises.

**Customer Premises Equipment (CPE)**

All telecommunication equipment located at a customer's location.

**Customer Provided Equipment (CPE)**

Equipment owned and maintained by the customer and located on their side of the End-User Point of Termination (EU-POT) network interface.

**Cyclic Redundancy Check (CRC)**

A method of checking the integrity of received data, where the check uses a polynomial algorithm based on the content of the data.

**Data Terminal Equipment (DTE)**

A generic term for customer terminal equipment that connects to the network through a modem or through digital Network Channel Terminating Equipment (NTCE), e.g., a computer or a PBX.

**dBm**

A decibel in which the reference power is one milliwatt. Decibel reference to one milliwatt.

**Digital Cross-Connect System (DCS)**

An intelligent (processor controlled) digital terminal that provides the capability to perform electronic cross-connects on digital channels operating at or below the bit rate of the transport systems terminated on the unit. This unit may also provide other features, e.g., bridging.

**Diversity**

Routing of customer circuits or access lines over physically separated facilities.

**End User**

The human being, organization, or telecommunications system that accesses the network in order to communicate via the services provided by the network.

**End-User POT (EU-POT)**

The Network Interface at the end-user's premises at which Qwest Communication, Inc.'s responsibility for the provision of service ends.

**Ethernet**

A packet-switched local network design (by Xerox Corp.) employing CSMA/CD as access control mechanism.

**Exchange Access Service (XA-Service)**

An access service provided by a LEC to an IXC to support the IC's interexchange service when the sending or receiving end user is served directly by the LEC network.

**Exchange Service**

Refers to end users served directly by LEC(s) communicating using a service in the exchange serving area, or LATA. The LEC offers the service to the end user.

**Explicit Forward Congestion Indication (EFCI)**

An indicator carried in the header of an ATM cell that shows whether or not that cell has passed through a BSS experiencing congestion.

**Facilities**

Facilities are the transmission paths between the demarcation points serving customer locations, a demarcation point serving a customer location and a Qwest Central Office, or two Qwest offices.

**Fiber Optic Terminal (FOT)**

The terminating or originating portion of a fiber optic system that performs both an electrical to optical conversion and a multiplexing function.

**Independent LEC (ILEC)**

A local exchange carrier (LEC) that is not a Bell Operating Company.

**Interexchange Carrier (IC, IEC, or IXC) or Interexchange Common Carrier**

Any individual, partnership, association, joint-stock company, trust, governmental entity or corporation engaged for hire in interstate or foreign communication by wire or radio, between two LATAs.

### **Interexchange Service**

Refers to end users located in different LATAs communicating using a specific service. An IC offers the service to the end user.

### **Local Access and Transport Area (LATA)**

A geographic area for the provision and administration of communications service. It encompasses designated exchanges that are grouped to serve common social, economic and other purposes.

### **Local Exchange Carrier (LEC)**

A carrier that provides telecommunications services within an exchange serving area (or LATA). BOCs and ILECs are referred to as LECs.

### **Local Area Network (LAN)**

Network permitting the interconnection and intercommunication of a group of computers, primarily for the sharing of resources such as data storage devices and printers.

### **LAN Switching Service (LSS)**

A basic ATM transport element designed to extend Local Area Networks (LANs) across a limited geographic area (within a LATA and single Wire Center).

### **Loop**

The physical, cable (copper or fiber) facilities that connect the Serving Wire Center to the customer's location.

### **Network Channel (NC) Code**

The Network Channel (NC) code is an encoded representation used to identify both switched and non-switched channel services. Included in this code set are customer options associated with individual channel services, or feature groups and other switched services.

### **Network Channel Interface (NCI) Code**

The Network Channel Interface (NCI) code is an encoded representation used to identify five (5) interface elements located at a Point of Termination (POT) at a central office or at the Network Interface at a customer location. The Interface code elements are: Total Conductors, Protocol, Impedance, Protocol Options, and Transmission Level Points (TLP). (At a digital interface, the TLP element of the NCI code is not used.)

**Network Element (NE)**

An independent and identifiable piece of equipment closely associated with at least one processor, and with a single location.

**Network Interface (NI)**

The demarcation point at the customer's premise where Qwest's responsibility for the provisioning of service ends.

**Network-Network Interface (NNI)**

The interface that connects two network nodes.

**Packet Switched Network**

A switched network that provides connection for forwarding standard data packets between user parties.

**Parity Check**

Making the number of ones in a grouping of bits either always even or always odd. This permits detection of bit groups that contain single errors. It may be applied to characters or blocks.

**Permanent Virtual Connection (PVC)**

An ATM connection that is established during provisioning of the circuit and torn down when the customer disconnects their ATM service.

**Physical Layer**

Layer one of the OSI model which allows the protocol to provide the transmission of information on the transmission facility. It is concerned with the physical and electrical characteristics of the interface.

**Physical Layer Convergence Protocol**

Physical Layer Convergence Protocol: the IEEE 802.6 defines The PLCP. It is used for DS3 transmission of ATM. ATM cells are encapsulated in a 125 microsecond frame defined by the PLCP which is defined inside the DS3 M-frame.

**Pipelining**

A process whereby parts of a packet are forwarded before the entire packet has been received.

**Point of Termination (POT)**

The physical telecommunications interface that establishes the technical interface, the test point(s), and the point(s) of operational responsibility. (See Network Interface).

**Point-To-Point**

A circuit connecting two (and only two) points.

**Port**

The physical point at which energy or signals enter or leave a device, circuit, etc.

**Premises**

Denotes a building or portion(s) of a building occupied by a single customer or end-user either as a place of business or residence.

**Protocol**

The rules for a communication system to operate that must be followed if communication is to occur; the complete interaction of all possible series of messages across an interface. Protocols may govern portions of a network, types of service, or administrative procedures.

**Protocol Code**

The Protocol (character positions 3 and 4 or the Network Channel Interface [NCI] Code) is a two-character alpha code that defines requirements for the interface regarding signaling and transmission.

**Protocol Data Unit (PDU)**

A unit of data that is exchanged between peer entities within a particular protocol level.

**Reassembly**

The process whereby no part of a packet is forwarded until the entire packet has been received.

**Service Integration**

The capability of providing multiple services using the same platform.

**Service Interworking**

The capability of interconnecting two customers that access different services (e.g., a Frame Relay customer communicating with an ATM customer.)

**Service Point**

Terminology used in tariff descriptions to describe geographic locations designated by Qwest where the Qwest ATM Cell Relay Network is to be accessed.

### **Serving Wire Center**

The term "Serving Wire Center" denotes the geographical area served by a Qwest Central Office from which dial tone for the local Exchange Service would normally be provided to the demarcation point on the property at which the customer is served.

### **Signaling**

The transmission of information to establish, monitor, or release connections and/or provide Network Control.

### **SONET**

Synchronous Optical Network (SONET): A standard providing electrical and optical specifications for the physical and higher layers, the first stage of which is at 51.84 Mbit/s, the Optical Channel 1 (OC1) level. Other rates, defined as OCn where n=3 through a number not yet firm, are possible.

### **Stand-Alone Access Link (SAAL)**

An ATM Stand-Alone Access Link connects customer facilities to the Qwest ATM network where a service provider other than Qwest Communications provides the customer's service. The SAAL is provided over copper, not fiber facilities. Private line transport mileage and/or a Central Office Connecting Channel (COCC) may be required in conjunction with a Stand-Alone Access Link in order to connect the customer's serving wire center, or node, with the serving wire center, or node of another ATM provider.

### **Stand-Alone Optical Access Link (SAOAL)**

An ATM Stand-Alone Optical Access Link connects customer facilities to the Qwest ATM network where a service provider other than Qwest Communications provided the service. The SAOAL is provided over fiber facilities. Private line transport mileage and/or a Central Office Connecting Channel (COCC) may be required in conjunction with a Stand-Alone Optical Access Link in order to connect the customer's serving wire center, or node, with the serving wire center, or node of another ATM provider.

### **Switched Virtual Connection (SVC)**

An ATM connection that is established when transmission is initiated and torn down when that transmission session is completed.

### **Token Ring**

A local network access mechanism and topology in which a token is passed from station to station in sequential order. Stations wishing to transmit must wait for the token to arrive before transmitting data. Throughout this document, the term "Token Ring" is used interchangeably with the IEEE Std. 802.5-1992 Edition.

**Transmission Control Protocol/Internet Protocol (TCP/IP)**

Internetworking software suite originated on the Department of Defense's Arpanet network. IP corresponds to Open Systems Interconnection (OSI) network Level 3, TCP to OSI Layer 4 and 5.

**Transparent LAN Service (TLS)**

A basic transport element designed to extend islands of Local Area Networks (LANs) across a limited geographic area (within a LATA and single Wire Center).

**Trunk**

A communications path connecting two switching systems in a network, used in the establishment of an end-to-end connection.

**Variable Bit Rate (VBR)**

An ATM Forum defined service category which supports variable bit rate data traffic with average and peak traffic parameters.

**Virtual Channel (VC)**

A logical association between the end points of a link (e.g., an ISSI transmission path) that enables unidirectional transfer of ATM cells over that link.

**Virtual Channel Connection (VCC)**

A concatenation of virtual channel links that extends between the points where the ATM service users access the ATM layer.

**Virtual Channel Link (VCL)**

A means of unidirectional transport of ATM cells between a point where a virtual channel identifier (VCI) value is assigned and the point where that value is translated or removed.

**Virtual Path (VP)**

A concept used to describe unidirectional transport of ATM cells belonging to virtual channels that are associated by a common identifier value.

**Virtual Path Connection (VPC)**

A concatenation of virtual path links that extends between the point where the values are assigned and the point where those virtual channel identifier values are translated or removed.

**Virtual Path Link (VPL)**

A means of unidirectional transport of ATM cells between the point where a VPI value is assigned and the point where that value is translated or removed.

**Wire Center**

A geographical area designated for local exchange service from a central office. This area is usually served by one central office, but it is possible to have multiple central offices serving the same area.

## CONTENTS

<b>Chapter and Section</b>	<b>Page</b>
10. References.....	10-1
10.1 American National Standards Institute Documents.....	10-1
10.2 Telcordia (Bellcore) Documents.....	10-1
10.3 Qwest Documents.....	10-2
10.4 ATM Forum Documents.....	10-2
10.5 International Telecommunications Union (ITU).....	10-2
10.6 Ordering Information.....	10-3



## 10. References

### 10.1 American National Standards Institute Documents

- ANSI T1.511-1994, *B-ISDN ATM Layer Cell Transfer - Performance Parameters.*
- ANSI T1.105-1995, *Telecommunications Digital Hierarchy - Optical Interface Rates and Formats Specifications (SONET).*
- ANSI T1.404-1994 *Customer Installation to Network, DS-3 Metallic Interface Specifications.*
- ANSI T1.223-1991, *Information Interchange — Structure and Representation of Network Channel (NC) and Network Channel Interface (NCI) Codes for the North American Telecommunications System.*
- ANSI T1.646-1995 *Broadband ISDN - Physical Layer Specification for User-Network Interfaces Including DS1/ATM*

### 10.2 Telcordia (Bellcore) Documents

- SR-3330, *Cell Relay Service Core Features, Issue 2, December 1996.*
- SR-3445, *Requirements for PVC Cell Relay Service, Issue 1, December 1994.*
- TA-TSV-001408, *Generic Requirements for Exchange PVC Cell Relay Service, Issue 1, August 1993.*
- TA-TSV-001409, *Generic Requirements for Exchange Access PVC Cell Relay Service , Issue 1, November 1993.*
- GR-1110-CORE, *Broadband Switching System (BSS) Generic Requirements., Issue 1, Revision 1, April 1996.*
- TR-NWT-001112, *Broadband ISDN User to Network Interface and Network Node Interface Physical Layer Generic Criteria , Issue 1, June 1993.*
- GR-1113-CORE, *Asynchronous Transfer Mode (ATM) and ATM Adaptation Layer (AAL) Protocols., Issue 1, July 1994.*
- GR-1248-CORE, *Generic Requirements for Operations of ATM Network Elements., Issue 3, August 1996.*
- GR-1117-CORE, *Generic Requirements for Exchange PVC CRS Service., Issue 1, June 1994.*
- GR-253-CORE, *Synchronous Optical Network (SONET) Transport Systems: Common Generic Criteria, Issue 2, December 1995.*

### 10.3 Qwest Documents

- Publication 77200     *Qwest DS1 Service and Qwest DS1 Rate Synchronization Service. Issue F, September 2001*
- Publication 77324     *Qwest DS3 Service. Issue D, September 2001*
- Publication 77332     *Self-Healing Network Service. Issue L, January 2001*
- Publication 77340     *Self-Healing Alternate Route Protection (SHARP). Issue F, September 2001*
- Publication 77346     *Synchronous Service Transport. Issue G, January 2001*
- Publication 77375     *1.544 Mbit/s Channel Interfaces. Issue E, September 2001*
- Publication 77386     *Expanded Interconnection and Collocation for Private Line Transport and Switched Access Services. Issue F, June 2001*

### 10.4 ATM Forum Documents

- ATM Forum,     *ATM User Network Interface Specification, Version 3.1, Prentice-Hall 1994.*
- ATM Forum,     *Traffic Management Specification, Version 4.0, April 1996.*
- ATM Forum,     *DS3 Physical Layer Interface Specification, March 1996.*
- ATM Forum,     *DS1 Physical Layer Specification, September 1994.*

### 10.5 International Telecommunications Union (ITU)

- ITU-T Recommendation I.610,     *OAM Principles of B-ISDN Access.*
- ITU-T Recommendation I.150,     *B-ISDN Asynchronous Transfer Mode Functional Characteristics.*
- ITU-T Recommendation I.361,     *B-ISDN ATM Layer Specifications.*

## 10.6 Ordering Information

All documents are subject to change and their citation in this document reflects the most current information available at the time of printing. Readers are advised to check status and availability of all documents.

Those who are not Qwest employees may order;

American National Standards Institute (ANSI) documents from:

American National Standards Institute  
Attn: Customer Service  
11 West 42nd Street  
New York, NY 10036  
Phone: (212) 642-4900  
Fax: (212) 302-1286

ANSI has a catalog available which describes their publications.

Telcordia documents from:

Telcordia Customer Relations  
8 Corporate Place, PYA 3A-184  
Piscataway, NJ 08854-4156  
Fax: (908) 336-2559  
Phone: (800) 521-CORE (2673) (U.S. and Canada)  
Phone: (908) 699-5800 (Others)  
Web: [www.telcordia.com](http://www.telcordia.com)

Qwest Technical Publications from:

<http://www.qwest.com/techpub>

- ATM Forum documents from:

ATM UNI 3.1 only:

Prentice Hall.  
ISBN 0-13-393828-X  
(515) 284-6751 or (800) 947-7700  
Fax No. (515) 284-2607

Other ATM Forum documents:

ATM Forum  
<http://www.atmforum.com>  
(415) 949-6700  
Fax on demand: (415) 688-4318

Employees of Qwest Communications International Inc. may order publications by submitting form RG 31-0033 to:

Central Distribution Center (CDC)  
1005 17th St., S-30  
Denver, CO 80202  
Phone: (303) 896-9446  
Fax: (303) 965-8652

Most Qwest publications are available to Qwest employees on the company network (E\*MEDIA). Call the (303) 624-4796 or email: [emedia@qwest.com](mailto:emedia@qwest.com) for further information.

### **10.7 Trademarks**

QWEST® Registered Trademark of Qwest Communications International Inc.