

# **Qwest Corporation Technical Publication**

## **Self-Healing Alternate Route Protection (SHARP)**

## NOTICE

This document describes Qwest Self-Healing Alternate Route Protection (SHARP) offered by Qwest Corporation to their customers. It covers distinguishing service features, technical specifications, and defines valid interfaces.

Qwest Corporation reserves the right to revise this document for any reason, including but not limited to, conformity with standards promulgated by various governmental or regulatory agencies; utilization of advances in the state of the technical arts; or to reflect changes in the design of equipment, techniques, or procedures described or referred to herein.

Liability to anyone arising out of use or reliance upon any information set forth herein is expressly disclaimed, and no representation or warranties, expressed or implied, are made with respect to the accuracy or utility of any information set forth herein.

This document is not to be construed as a suggestion to any manufacturer to modify or change any of its products, nor does this publication represent any commitment by Qwest Corporation to purchase any specific products. Further, conformance to this publication does not constitute a guarantee of a given supplier's equipment and/or its associated documentation.

Future issues of Technical Publication 77340 will be announced to the industry at least 15 days prior to the issuance date. This notice, which will come through our standard customer notification channels, will allow the customer time to comment on the proposed revisions.

Ordering information for Qwest Publications can be obtained from the Reference Section of this document.

If further information is required, please contact:

Qwest Corporation  
700 W Mineral Ave.  
Littleton, CO 80120  
Fax: (303)-707-9498  
E-mail: [techpub@qwest.com](mailto:techpub@qwest.com)

Throughout this publication, the term Qwest signifies Qwest Corporation



COMMENTS on PUB 77340

PLEASE TEAR OUT AND SEND YOUR COMMENTS/SUGGESTIONS TO:

Qwest Corporation  
700 W Mineral Ave.  
Littleton, CO 80120  
Fax: (303)-707-9498  
E-mail: techpub@qwest.com

Information from you helps us to improve our Publications. Please take a few moments to answer the following questions and return to the above address.

Was this Publication valuable to you in understanding the technical parameters of our service?	YES _____	NO _____
Was the information accurate and up-to-date?	YES _____	NO _____
Was the information easily understood?	YES _____	NO _____
Were the contents logically sequenced?	YES _____	NO _____
Were the tables and figures understandable and helpful	YES _____	NO _____
Were the pages legible?	YES _____	NO _____

If you answered NO to any of the questions and/or if you have any other comments or suggestions, please explain:

---

---

---

---

(Attach additional sheet, if necessary)

Name \_\_\_\_\_ Date \_\_\_\_\_

Company \_\_\_\_\_

Address \_\_\_\_\_

Telephone Number \_\_\_\_\_

E-mail \_\_\_\_\_

## CONTENTS

Chapter and Section	Page
1. Introduction .....	1-1
1.1 General.....	1-1
1.2 Reason For Reissue .....	1-1
1.3 End-User and Carrier Customer Premises - Mandated DS1 Differences.....	1-1
1.4 Special Information about the End-User DSX-1 Interface.....	1-1
2. Description of Service .....	2-1
2.1 Applicability of Technical Specifications.....	2-1
2.2 Description of Service.....	2-1
2.3 Service Configurations .....	2-2
3. Network Interfaces (NIs) .....	3-1
3.1 Description of Interface .....	3-1
3.1.1 DS3 Interface.....	3-1
3.1.2 DS1 Interface.....	3-1
3.1.3 Optical Interface .....	3-2
3.2 NCI Code Form and Components.....	3-3
3.3 NC Code Function and Formats.....	3-8
3.4 SPEC Code Function and Format.....	3-8
4. Performance Specifications.....	4-1
4.1 Error Performance Parameters .....	4-1
4.2 Error Performance Requirements.....	4-1
4.3 Service Availability.....	4-2
4.4 Jitter Performance .....	4-2
4.4.1 Definition of Timing Jitter .....	4-2
4.4.2 Network Interface Timing Jitter Specifications .....	4-2
4.5 Protection Switching.....	4-2
5. Maintenance.....	5-1
5.1 Customer Responsibilities.....	5-1
5.2 Qwest Responsibilities.....	5-1
6. Definitions.....	6-1
6.1 Acronyms.....	6-1
6.2 Glossary .....	6-2

**CONTENTS (Continued)**

<b>Chapter and Section</b>	<b>Page</b>
7. Reference .....	7-1
7.1 American National Standard Institute Documents.....	7-1
7.2 Telcordia Documents.....	7-1
7.3 International Telecommunication Union - Telecommunication Standardization Sector (ITU-T) Recommendations .....	7-2
7.4 Qwest Technical Publications .....	7-2
7.5 Ordering Information .....	7-2
7.6 Trademarks.....	7-3

**Figures**

2-1 Standard DS3 Service Configurations .....	2-3
2-2 Self-Healing Alternate Route Protection (SHARP).....	2-4
2-3 End-to-End Circuit Protection (SHARP) .....	2-5
2-4 Partial/One-End Only Facilities Protection (SHARP PLUS).....	2-6
2-5 SHARP PLUS Interoffice Facility Protection Only .....	2-7
2-6 Transport Alternate Path Protection .....	2-8
3-1 Electrical/Optical Interface .....	3-3
3-2 SPEC Code Format .....	3-9

**Tables**

3-1 Electrical DS3 NCI Code Example .....	3-4
3-2 DS3 Compatible Network Channel Interface (NCI) Code Combinations.....	3-5
3-3 DS1 Compatible Network Channel Interface (NCI) Code Combinations.....	3-5
3-4 DS1 Compatible Network Channel (NC) Codes .....	3-10
3-5 DS3 Compatible Network Channel (NC) Codes .....	3-11

## CONTENTS

<b>Chapter and Section</b>	<b>Page</b>
1. Introduction .....	1-1
1.1 General.....	1-1
1.2 Reason For Reissue .....	1-1
1.3 End-User and Carrier Customer Premises - Mandated DS1 Differences .....	1-1
1.4 Special Information about the End-user DSX-1 Interface.....	1-1



## **1. Introduction**

### **1.1 General**

This document describes Qwest Self-Healing Alternate Route Protection Service offered by Qwest Corporation. It covers distinguishing service features, technical specifications, and defines valid interfaces.

The purpose of this document is to describe Qwest Self-Healing Alternate Route Protection Service appropriate for the majority of applications. Sufficient technical detail is furnished to allow a customer, such as an Interexchange Carrier (IC) or End-User (EU), to select a service that may be incorporated into an end-to-end communications channel. It is not the intent of this document to provide specific ordering information, but to describe the technical features of this service offering.

### **1.2 Reason For Reissue**

- Change the Qwest default optical connector from FC to SC
- Add an LC connector option for customer premises locations

### **1.3 End-User and Carrier Customer Premises - Mandated DS1 Differences**

Both End-Users and Carriers may purchase 1.544 Mbit/s (DS1) channels with a number of optional enhancements.

Federal Regulations mandate certain technical differences between interfaces provided at End-User premises and at Carrier premises, and these differences are explained in Qwest Technical Publication 77375, *1.544 Mbit/s Channel Interfaces*, Issue G, June 2008. The differences have no qualitative affect on the service being provided.

When a Carrier orders services, not for resale but for their own internal use, the appropriate End-User interface(s) should be ordered.

### **1.4 Special Information about the End-user DSX-1 Interface**

Qwest has developed a new interface to meet DS1 customer needs at end-user customer premises where the customer location is served by fiber facilities with associated multiplexer. This new interface eliminates the requirement for a customer provided Channel Service Unit. If copper facilities are the only access into your building, fiber facilities must be requested; however, Special Construction Charges will be assessed before the fiber construction can begin.

In order to determine whether this interface is an alternative for your location, please contact your Qwest Marketing Representative or call the Qwest Business Office. For further technical description please refer to Qwest Technical Publication 77375.

## CONTENTS

Chapter and Section	Page
2. Description of Service .....	2-1
2.1 Applicability of Technical Specifications.....	2-1
2.2 Description of Service.....	2-1
2.3 Service Configurations .....	2-2

### Figures

2-1 Standard DS3 Service Configuration .....	2-3
2-2 Self-Healing Alternate Route Protection (SHARP).....	2-4
2-3 End-To-End Circuit Protection (SHARP PLUS) .....	2-5
2-4 Partial/One-End Only Facilities Protection (SHARP PLUS).....	2-6
2-5 SHARP PLUS Interoffice Facility Protection Only .....	2-7
2-6 Transport Alternate Path Protection .....	2-8



## **2. Description of Service**

### **2.1 Applicability of Technical Specifications**

The technical specifications presented in this document are applicable to Qwest Self-Healing Alternate Route Protection (SHARP) Service only . It does not attempt to describe the various types of transmission equipment used to provide this service.

### **2.2 Description of Service**

Self-Healing Alternate Route Protection (SHARP) is an optional service that improves the reliability of DS1 or DS3 services that are transported over fiber optic facilities. This feature provides a separate facility path for the protection system between the Serving Wire Center (SWC) and the Qwest Point of Termination (POT) located in the same building as the customer designated premises.

This added protection is provided by ensuring that backup electronics and two physically separate facility paths are used in the provisioning of the service. One primary (or working) service path is established between the SWC and the customer designated premises. In addition, a protect path is provisioned between the customer designated premises and the SWC via a Qwest designated Alternate Wire Center (AWC) where available.

All SHARP Plus options as described in this document that were previously available have been grandfathered and are limited to existing SHARP Plus contract customers. SHARP Interoffice Facility Protection, SHARP Plus, extends the local loop protection provided by the basic SHARP option to include protection of Transport Channel (interoffice) facilities between SWCs. This option, coupled with the SHARP option on each end of the circuit, will provide end-to-end service protection for DS1 and DS3 services.

SHARP PLUS Interoffice Facility Protection Only will provide an alternate path, in addition to a primary DS3 private line, on an "Interoffice Only" basis. SHARP PLUS Interoffice Facility Protection Only is available on DS3 services only. The primary and the alternate paths will be provided on fiber optic facilities and will require a minimum separation (25 feet) between the primary and alternate paths of transmission.

Transport Alternate Path Protection is also available on DS3 services only. Transport Alternate Path Protection will provide an alternate path for the DS3 circuit, in addition to the primary DS3 fiber optic private line, on an interoffice basis only. The alternate path will be provided on microwave radio facilities.

### 2.3 Service Configurations

The Qwest Self-Healing Alternate Route Protection Service may utilize both interoffice and local loop facilities. It will interface at an electrical DS3 or DS1 level. An optical interface will also be offered on fiber optic systems dedicated to single customers. In the event that an optical interface is selected, the standard service interval offered for this service may not apply due to the incompatibility between the customer's equipment and equipment pre-provisioned by Qwest at the SWC.

When DS3 or DS1 Service is normally provided over fiber optic facilities, the working and protection systems are in the same cable as shown in Figure 2-1.

Customers electing SHARP will have their DS3 or DS1 Service routed to a protection system that takes a completely separate route back to the SWC. This configuration provides protection for the local loop or channel termination and is shown in Figure 2-2.

Equipment located on the customer's premises will have a single cable entrance unless the building owner elects to provide two physically separated cable entrances to the building.

SHARP Interoffice Facility Protection will consist of SHARP protection for the local loop portion of the circuit, SWC protection and protection of the Transport Channel Facilities used to connect each SWC. This option may be ordered to provide end-to-end circuit protection (SHARP Plus) as shown in Figure 2-3 and is no longer available. Partial, or one-end facilities protection, terminating in a Qwest Serving Wire Center may also be ordered and is shown in Figure 2-4. This option is no longer available.

SHARP Interoffice Facility Protection Only will consist of SHARP protection for the DS3 Transport Channel Facilities used to connect each SWC. This option is shown in Figure 2-5 and is no longer available.

Transport Alternate Path Protection will consist of SHARP protection for the DS3 Transport Channel Facilities used to connect each Wire Center (WC) with the protection channel provided on radio facilities. This option is shown in Figure 2-6.

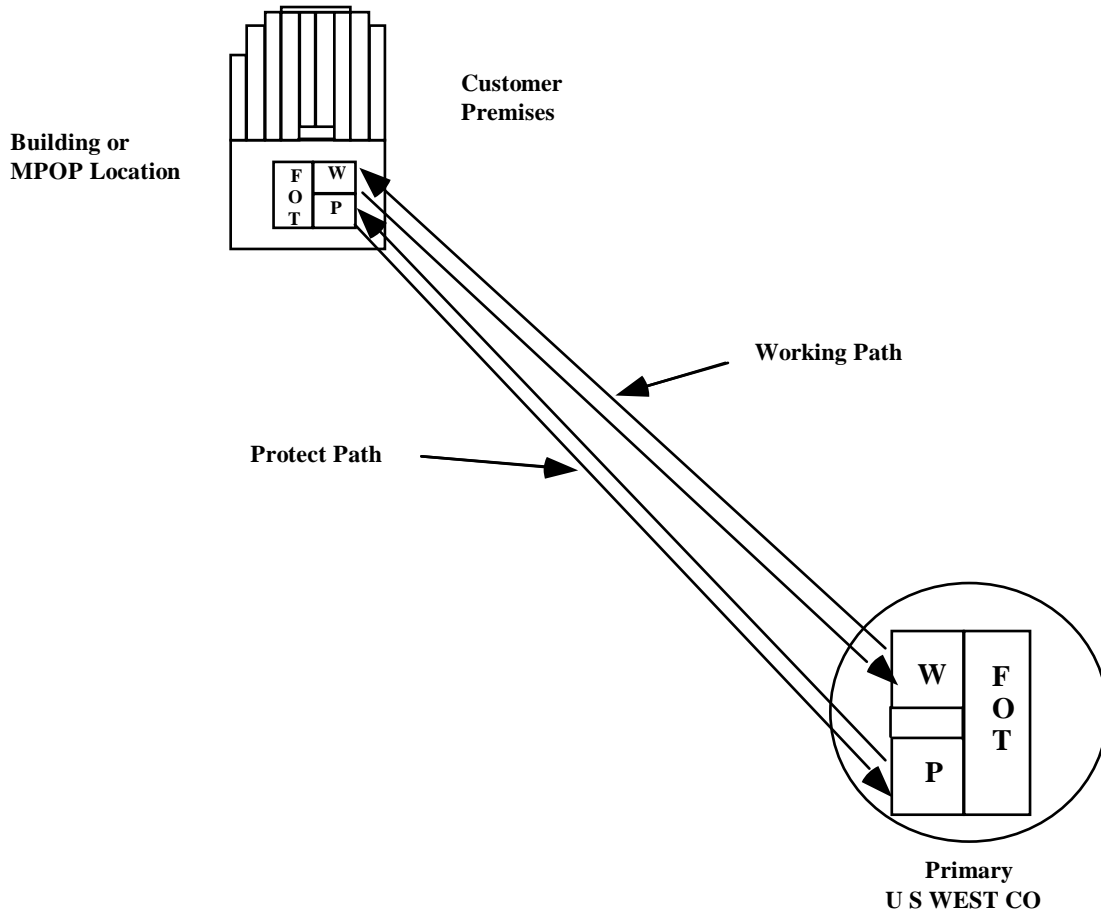

LEGEND	
FOT	= FIBER OPTIC TERMINAL
MPOP	= MAIN POINT OF PRESENCE
P	= PROTECTION TERMINAL
W	= WORKING

Figure 2-1 Standard DS3 Service Configuration

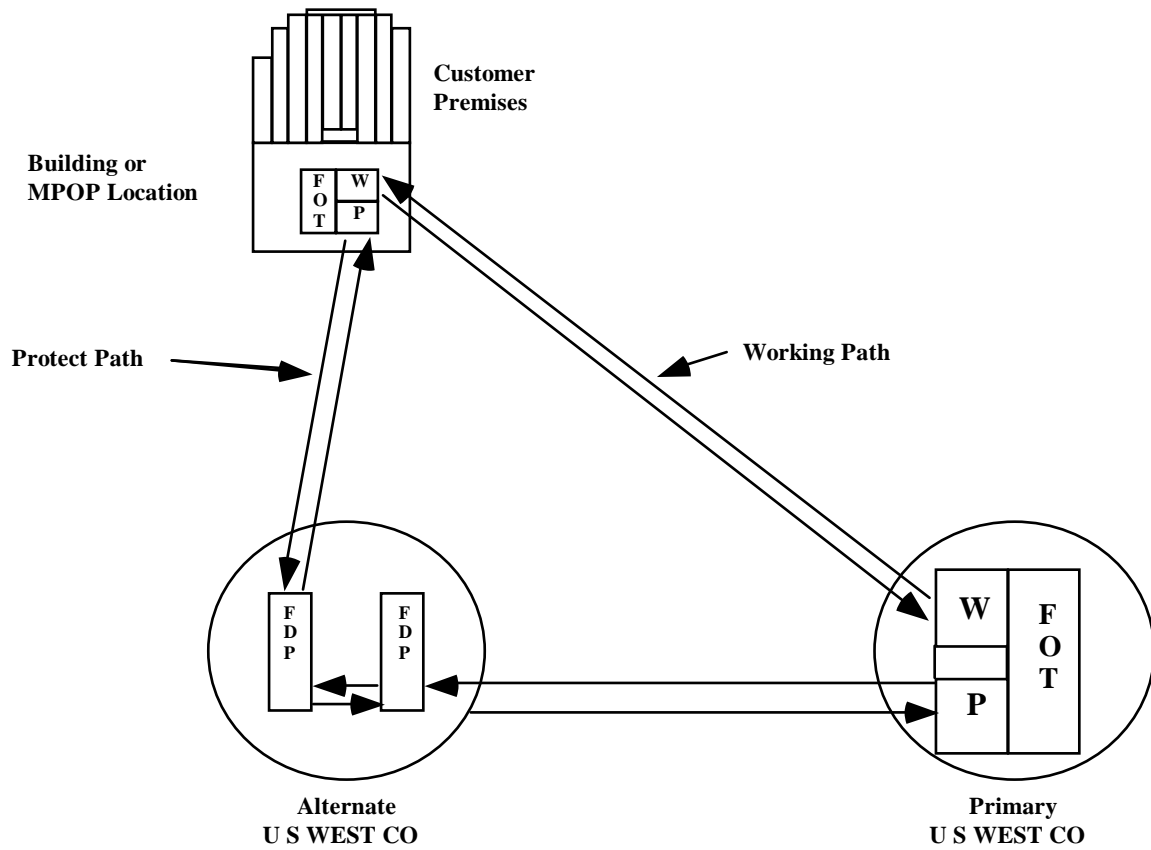

<u>LEGEND</u>	
FDP	= FIBER DISTRIBUTION PANEL
FOT	= FIBER OPTIC TERMINAL
MPOP	= MAIN POINT OF PRESENCE
W	= WORKING TERMINAL
P	= PROTECTION

**Figure 2-2** Self-Healing Alternate Route Protection (SHARP)

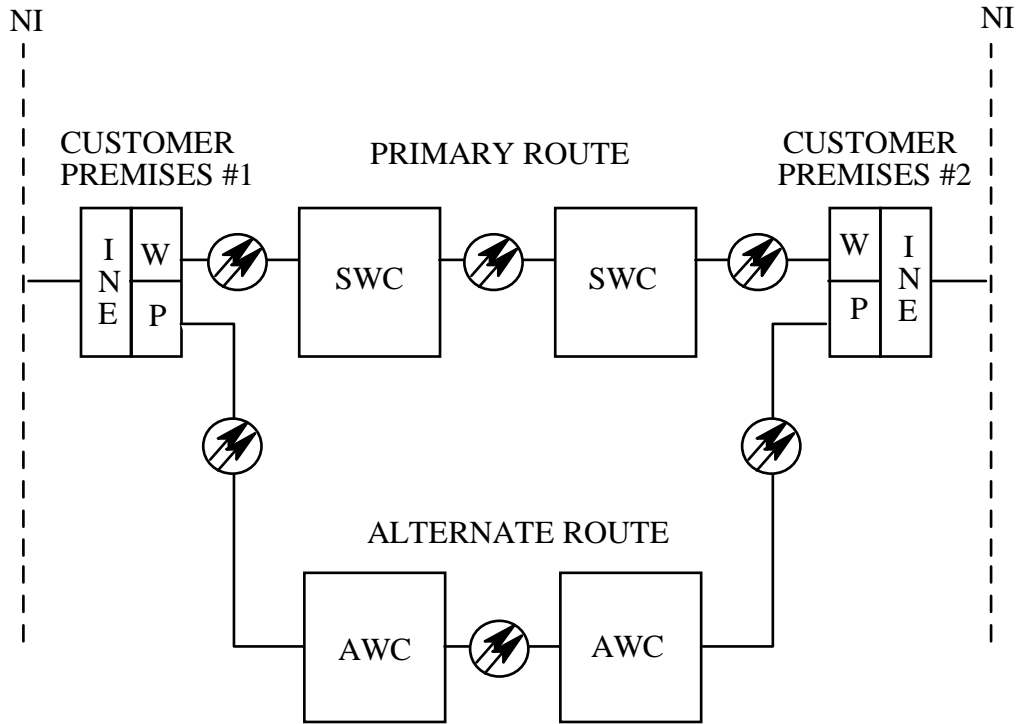

<u>LEGEND</u>	
AWC	= ALTERNATE WIRE CENTER
INE	= INTELLIGENT NETWORK ELEMENT
NI	= NETWORK INTERFACE
P	= PROTECTION TERMINAL
SWC	= SERVING WIRE CENTER
W	= WORKING TERMINAL
	= FIBER FACILITIES

**Figure 2-3** End-To-End Circuit Protection (SHARP PLUS)

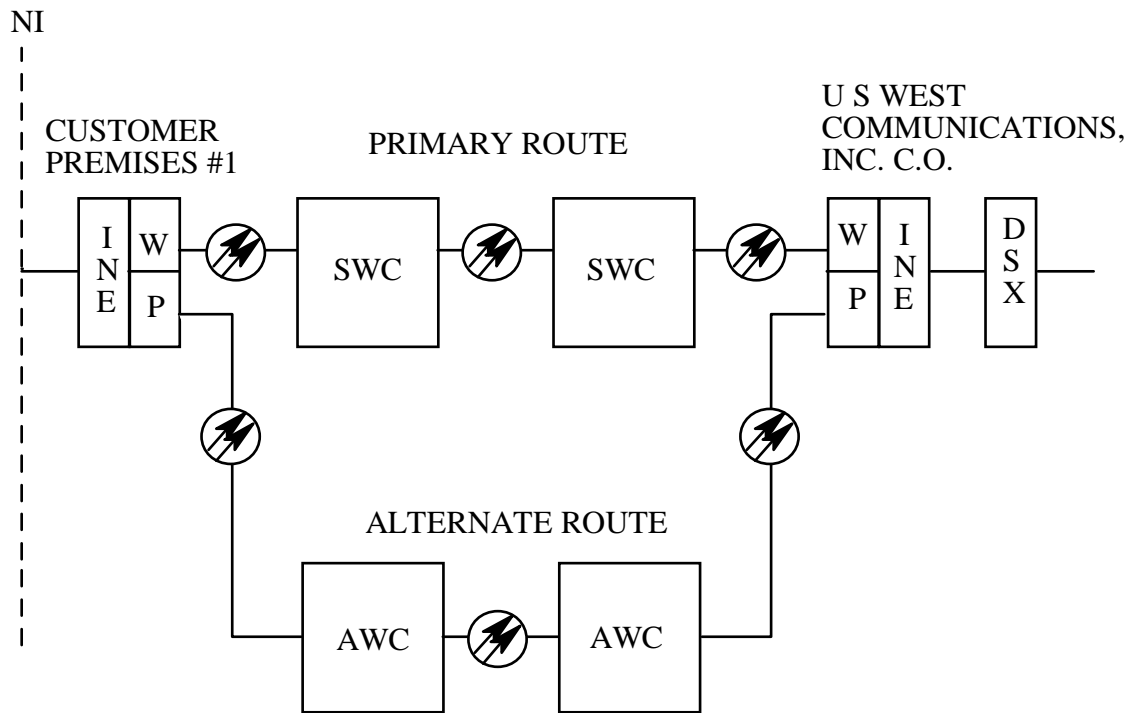

<u>LEGEND</u>	
AWC	= ALTERNATE WIRE CENTER
DSX	= DIGITAL SIGNAL CROSS-CONNECT
INE	= INTELLIGENT NETWORK ELEMENT
NI	= NETWORK INTERFACE
P	= PROTECTION TERMINAL
SWC	= SERVING WIRE CENTER
W	= WORKING TERMINAL
	= FIBER FACILITIES

**Figure 2-4** Partial/One-End Only Facilities Protection (SHARP PLUS)

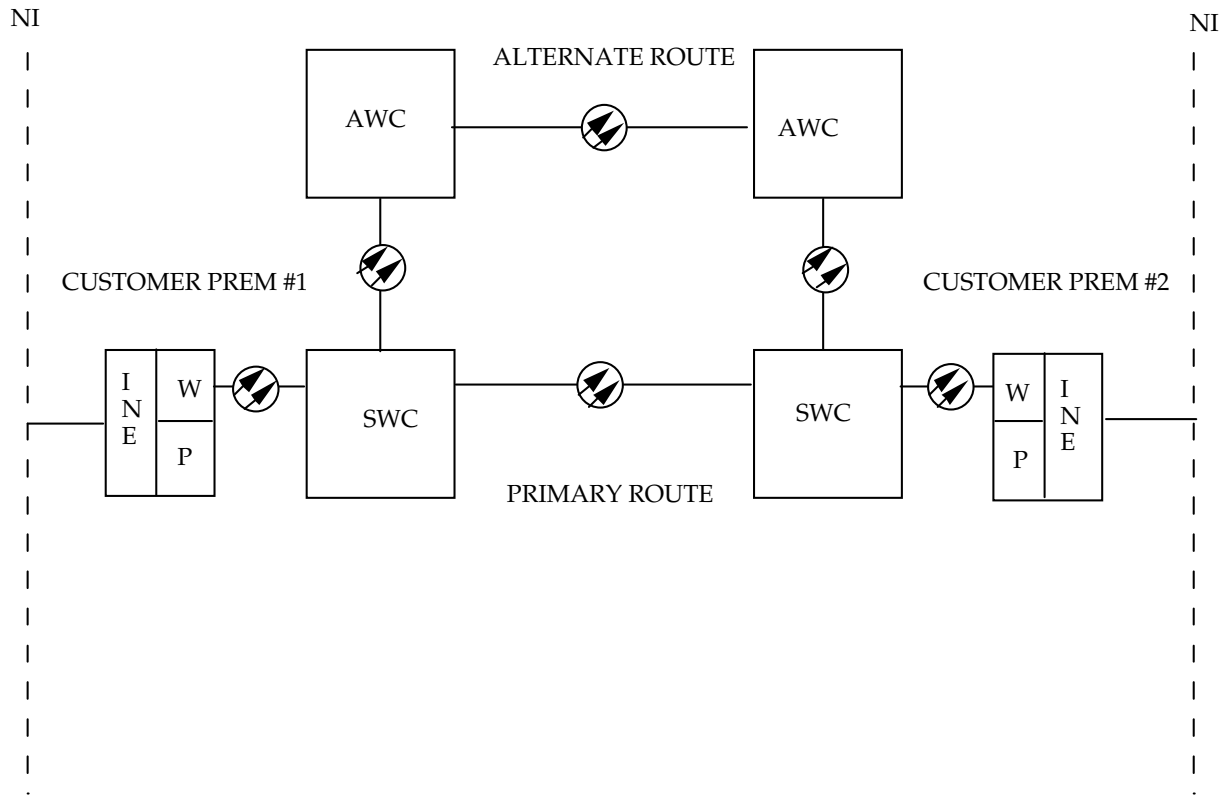

<u>LEGEND</u>	
AWC	= ALTERNATE WIRE CENTER
DSX	= DIGITAL SIGNAL CROSS-CONNECT
INE	= INTELLIGENT NETWORK ELEMENT
NI	= NETWORK INTERFACE
P	= PROTECTION TERMINAL
SWC	= SERVING WIRE CENTER
W	= WORKING TERMINAL
	= FIBER FACILITIES

**Figure 2-5** SHARP PLUS Interoffice Facility Protection Only

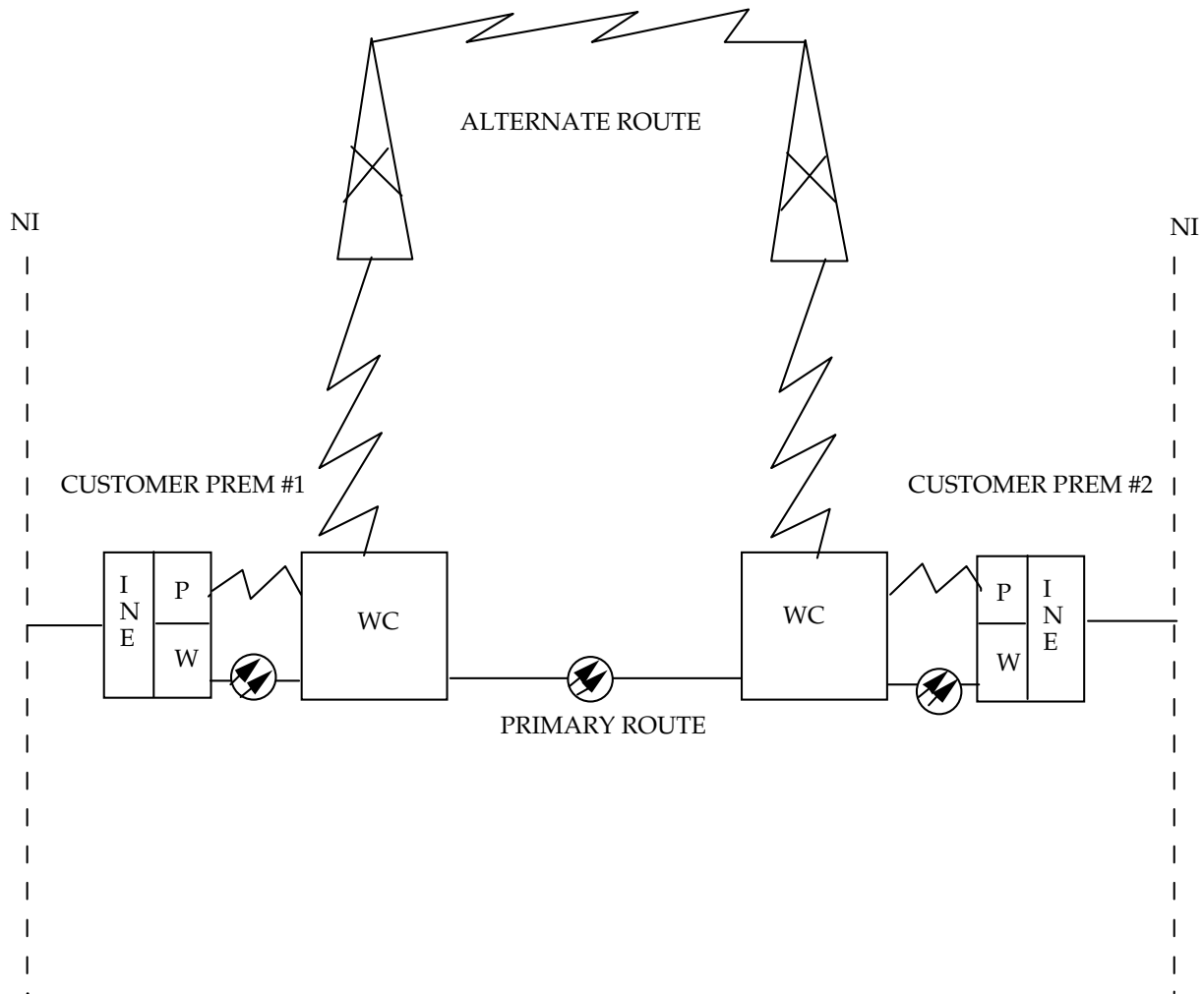



LEGEND	
AWC	= ALTERNATE WIRE CENTER
INE	= INTELLIGENT NETWORK ELEMENT
NI	= NETWORK INTERFACE
P	= PROTECTION TERMINAL
WC	= WIRE CENTER
W	= WORKING TERMINAL
	= FIBER FACILITIES
	= MICROWAVE RADIO FACILITIES

Figure 2-6 Transport Alternate Path Protection

## CONTENTS

Chapter and Section	Page
3. Network Interfaces (NIs) .....	3-1
3.1 Description of Interface .....	3-1
3.1.1 DS3 Interface .....	3-1
3.1.2 DS1 Interface .....	3-1
3.1.3 Optical Interface .....	3-2
3.2 NCI Code Form and Components.....	3-3
3.3 NC Code Function and Format.....	3-8
3.4 SPEC Code Function and Format .....	3-8

### Figure

3-1 Electrical/Optical Network Interface .....	3-3
3-2 SPEC Code Format .....	3-9

### Tables

3-1 Electrical DS3 NCI Code Example .....	3-4
3-2 DS3 Compatible Network Channel Interface (NCI) Code Combinations.....	3-5
3-3 DS1 Compatible Network Channel Interface (NCI) Code Combinations.....	3-5
3-4 DS1 Compatible Network Channel (NC) Codes .....	3-10
3-5 DS3 Compatible Network Channel (NC) Codes .....	3-11



### **3. Network Interfaces (NIs)**

#### **3.1 Description of Interface**

The allowable interface for Qwest Self-Healing Alternate Route Protection Service will be at the electrical DS3 level or DS1 level. An optical interface at the system level will also be available for customers with Synchronous Service Transport (SST).

Qwest Tech Pub 77368, *CUSTOMER PREMISES ENVIRONMENTAL SPECIFICATIONS AND INSTALLATION GUIDE*, describes the environmental and installation requirements as well as the powering and grounding options for Qwest telecommunications equipment placed on customer premises.

Qwest Tech Pub 77419, *SPECIFICATIONS FOR THE PLACEMENT OF QWEST EQUIPMENT IN CUSTOMER-OWNED OUTDOOR CABINETS*, describes the environmental (including electromagnetic compatibility), power, and grounding requirements for customer-owned outdoor cabinets (if provided) in order to allow the placement of Qwest-owned equipment inside these cabinets for the provisioning of SHARP to the customer.

##### **3.1.1 DS3 Interface**

DS3 channels are provided to Carriers and to End-Users (EUs) premises.

The NI to a Carrier customer will be at the end of a DSX-3 jumper with signal characteristics described in Qwest Technical Publication 77324, issue F. The NI to an EU customer will be SJA44 connectors with signal characteristics described in Qwest Technical Publication 77324, issue F.

Permissible frame formats for Carriers and EUs are described in ANSI T1.107-2002 "Telecommunication - Digital Hierarchy - Format Specifications." and ANSI T1.404-2002 (see Reference Section) for the DS3 rate.

##### **3.1.2 DS1 Interface**

DS1 channels are provided to Carriers and to End-Users (EUs) premises.

The Network Interface (NI) at a Carrier premises will be at the end of a DSX-1 jumper wire or cable with signal characteristics described in Qwest Technical Publication 77375. Qwest Technical Publication 77375, issue F, provides additional information pertaining to the DS1 NI configuration.

The NI at an EU customer premises may be either a Conventional Interface or a DSX-1 interface. Signal characteristics, limitations, and the physical means of connection at the NI for each interface are described in Qwest Technical Publication 77375, issue F, which should be studied before a selection is made. The Conventional Interface uses one of the Registration Jacks described by the three Universal Service Ordering Codes (USOC) RJ48C, RJ48M and RJ48H. The selection of one of these jacks is a customer option or that of their Vendor.

Permissible frame formats for Carriers and EUs are described in ANSI T1.107-2002 "Telecommunication - Digital Hierarchy - Format Specifications" and in ANSI T1.403-1999 (see Reference Section) for the DS1 rate.

### **3.1.3 Optical Interface**

The NI for this option will be at a Qwest-provided Fiber Distribution Panel (FDP) at the customer's location. The fiber optic cable shall be equipped to terminate SC, FC or LC UPC duplex connectors. SC/UPC (with Ultra Physical Contact polish) is the Qwest default connector for new SHARP optical interfaces whereas FC and LC are customer-specified options, where available at premises locations only. The customer will provide the fiber optic patch cords to connect their equipment to the NI. The customer's equipment will be cross-connected at the Qwest provided FDP as shown in Figure 3-1.

Qwest will use Synchronous Optical Network (SONET) compliant equipment to provision this service. When ordered in conjunction with SST optical meets, consultation between Qwest Transmission Engineers and the Customer's Transmission Engineer will be required to ensure compatible equipment at both ends of the system. The transmission standard employed will be the SONET as defined in the ANSI T1.105.2001 which defines the North American version of the Synchronous Digital Hierarchy (SDH). This interface is also in accordance with ANSI T1.106-1988, the American National Standard for Optical Interface Specifications. This technology allows Qwest to transport, provision and deliver the DS1 and DS3 interfaces over SONET transport.

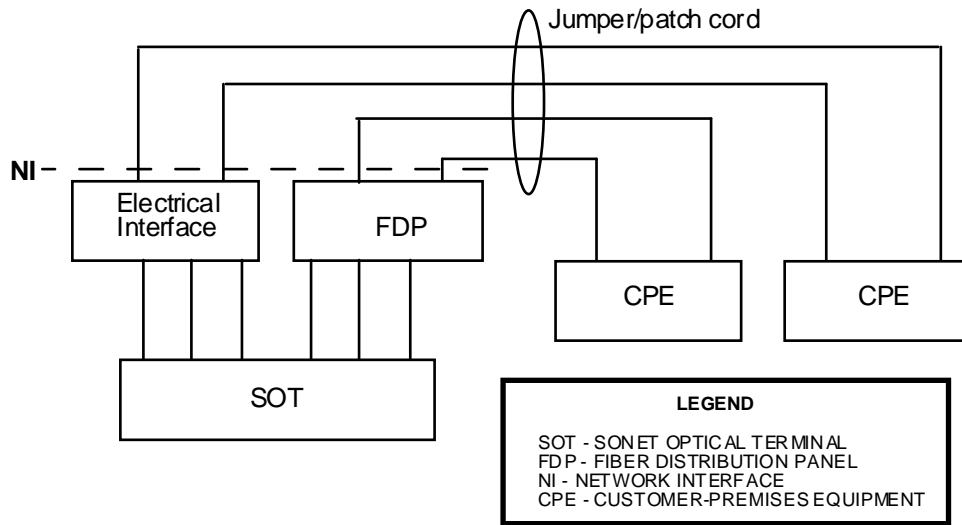

**Figure 3-1** Electrical/Optical Network Interface

### 3.2 NCI Code Form and Components

The full NCI code format has fields not used for digital services. Only those fields relevant to digital interfaces are discussed here.

An NCI code has the form 04DS6.44. The period between the numbers is a delimiter, which is used for improved clarity. It causes the Protocol Option Code, discussed later, to stand out. An NCI code has no dashes (-).

Digital NCI Codes have four components. Table 3-1 provides an example of an electrical DS3 interface NCI code. For complete information on DS1, refer to Technical Publication 77375, 1.544 Mbit/s (DS1) Channels. For complete DS3 information, refer to Technical Publication 77324, Technical Specifications for 44.736 Mbit/s (DS3) Electrical, Optical and Radio Interfaces.

The following example, 04DS6.44 , is the DS3 M23 multiplex application without C-Bit Parity

**Table 3-1** Electrical DS3 NCI Code Example

<b>DS3 Electrical Interface:</b>	
04 =	4 Conductors - Number of wires at the interface. For DS3, the code is always 04 denoting a 4-wire interface.
DS =	Digital Hierarchy Interface - Protocol Code. This code is always DS for electrical DS3 interfaces.
6 =	75 Ohm Impedance - Impedance. For DS3 interfaces, the code is always 6 denoting 75 Ohms. The period following the 6 is a delimiter for clarity.
44 =	44.736 Mbit/s (DS3) Format per ANSI T1.102-1987 - Protocol Option Code. This code is a variable. 44 denotes the DS3 rate of 44.736 Mbit/s, and it denotes the application. A suffix may denote an application option or Capacity.

The compatible DS3 Network Channel Interface (NCI) codes for Qwest Self-Healing Alternate Route Protection Service are listed in Table 3-2. This is a partial list consisting of what is viewed as the interface most likely to be used with this service. Refer to Qwest Technical Publication 77324 - DS3 Electrical Interface for additional information as well as Technical Publication 77346, *Qwest Synchronous Service Transport (SST)* for SONET optical interface NCI codes.

**Table 3-2** DS3 Compatible Network Channel Interface (NCI) Code Combinations

<u>Electrical Interface</u>	
<u>NCI</u>	<u>SECNCI</u>
04DS6.44	04DS6.44

The compatible DS1 NCI codes for Qwest Self-Healing Alternate Route Protection Service are listed in Table 3-2. This is a partial list consisting of what is viewed as the interfaces most likely to be used with this service. Refer to Qwest Technical Publication 77200 for additional information on the DS1 interface.

(Partial List - See Publication 77200, Qwest DS1 Service, for complete DS1 Electrical Interface Information)

**Table 3-3** DS1 Compatible Network Channel Interface (NCI) Code Combinations

<u>Carrier To Carrier</u>		
<u>NCI</u>	<u>SECNCI</u>	
04DS9.15	04DS9.15	DS1 Access (Carrier Premises) Interface, AMI/SF
04DS9.15K	04DS9.15K	DS1 Access (Carrier Premises) Interface, AMI/Non-ANSI ESF
04DS9.15S	04DS9.15S	DS1 Access (Carrier Premises) Interface, B8ZS/Non-ANSI ESF**
04DS9.15Z	04DS9.15Z	DS1 Access (Carrier Premises) Interface, ZBTSI/ESF**
** Provides Clear Channel Capability		

Table 3-3 continues to next page

**Table 3-3 DS1 Compatible Network Channel Interface (NCI) Code Combinations**

<u>Carrier To End-User</u>		
<u>NCI</u>	<u>SECNCI</u>	
04DS9.15	04DU9.B	DS1 Access (End-User Premises) Interface, SF/AMI, with Line Power
	04DU9.BN	DS1 Access (End-User Premises) Interface, SF/AMI, without Line Power
	04DU9.BX	DS1 Access (End-User Premises) Interface; SF/AMI/DSX-1 Interface
04DS9.15K	04DU9.C	DS1 Access (End-User Premises) Interface, non-ANSI ESF/AMI, with Line Power
	04DU9.CN	DS1 Access (End-User Premises) Interface, non-ANSI ESF/AMI, without Line Power
	04DU9.CX	DS1 Access (End-User Premises) Interface; non-ANSI ESF/AMI/DSX-1 Interface
04DS9.15S	04DU9.S	DS1 Access (End-User Premises) Interface, B8ZS/Non-ANSI ESF, with Line Power**
	04DU9.SN	DS1 Access (End-User Premises) Interface, B8ZS/Non-ANSI ESF, without Line Power**
	04DU9.SX	DS1 Access (End-User Premises) Interface, B8ZS/Non-ANSI ESF/DSX-1 Interface**
04DS9.15Z	04DU9.Z	DS1 Access (End-User Premises) Interface, ZBTSI/ESF, with Line Power**
	04DU9.ZN	DS1 Access (End-User Premises) Interface, ZBTSI/ESF, without Line Power**
	04DU9.ZX	DS1 Access (End-User Premises) Interface, ZBTSI/ESF/DSX-1 Interface**
** Provides Clear Channel Capability		

Table 3-3 continues to next page

**Table 3-3** DS1 Compatible Network Channel Interface (NCI) Code Combinations

<u>End-User To End-User</u>		
<u>NCI</u>	<u>SECNCI</u>	
04DU9.B	04DU9.B	DS1 Access (End-User Premises) Interface, SF/AMI, with Line Power
04DU9.BN	04DU9.BN	DS1 Access (End-User Premises) Interface, SF/AMI, without Line Power
04DU9.BX	04DU9.BX	DS1 Access (End-User Premises) Interface; SF/AMI/DSX-1 Interface
04DU9.C	04DU9.C	DS1 Access (End-User Premises) Interface, non-ANSI ESF/AMI, with Line Power
04DU9.CN	04DU9.CN	DS1 Access (End-User Premises) Interface, non-ANSI ESF/AMI, without Line Power
04DU9.CX	04DU9.CX	DS1 Access (End-Use Premises) Interface; non-ANSI ESF/AMI/DSX-1 Interface
04DU9.S	04DU9.S	DS1 Access (End-User Premises) Interface, B8ZS/Non-ANSI ESF, with Line Power**
04DU9.SN	04DU9.SN	DS1 Access (End-User Premises) Interface, ANSI ESF/B8ZS without Line Power
04DU9.SX	04DU9.SX	DS1 Access (End-User Premises) Interface, ANSI ESF/B8ZS/DSX-1 Interface
04DU9.Z	04DU9.Z	DS1 Access (End-User Premises) Interface, ZBTSI/ESF, with Line Power**
04DU9.ZN	04DU9.ZN	DS1 Access (End-Use Premises) Interface; non-ANSI ESF/ZBTSI/AMI without Line Power**
04DU9.ZX	04DU9.ZX	DS1 Access (End-Use Premises) Interface; non-ANSI ESF/ZBTSI/AM I/DSX-1 Interface**
** Provides Clear Channel Capability		

## Definitions of NCI Code Components

02	=	2 Conductors
04	=	4 Conductors
DS	=	Digital Hierarchy Interface
DU	=	Digital Access Interface
FC	=	Fiber Optic Interface
F	=	Fiber
6	=	75 Ohm Impedance
9	=	100 Ohm Impedance
15	=	1.544 Mbit/s (DS1) Superframe (SF) Format per Technical Reference TR-INS-000342 *
44	=	44.736 Mbit/s (DS3) Format per ANSI T1.102-1993

### 3.3 NC Code Function and Format

Primarily, service considerations are encoded into Network Channel (NC) codes. The NC code is an encoded representation used to identify both switched and non-switched channel services. Included in this code set are customer options associated with individual channel services, or feature groups and other switched services. The NC code is specified by the customer to advise Qwest of the required service connection of the channel.

An NC code consists of four alpha/numeric characters, which may include a dash (-). There are neither spaces nor delimiters between the characters.

- For electrical channel DS1 interfaces, the first two characters are HC. For additional information, see Technical Publication 77200.
- For electrical channel DS3 interfaces, the first two characters are HF. For additional information, see Technical Publication 77324.

The third and fourth characters are variable to denote additional protocols and service features as described in the following sections.

The NC codes for the service desired must be specified by the customer when ordering High Capacity Digital Special Access services. This section describes the NC codes which apply specifically to SHARP.

### 3.4 SPEC Code Function and Format

Service and Product Enhancement Codes (SPEC) will be used in conjunction with NC and NCI codes to order Transport Alternate Protection Path service. The SPEC code will be used to indicate a mixed technology situation. SPEC codes will be used to identify product features and options other than those identifiable by the NC and NCI codes. Figure 3-2 depicts the basic SPEC Format.

CHARACTER POSITION	1	2	3	4	5	6	7
CODE	A/N	A/N	A/N	A/N	A/N	A/N	A/N

DATA							
ELEMENT							
		</					

The compatible DS1 Network Channel (NC) codes for Qwest Self-Healing Alternate Route Protections Service are listed in Table 3-4

### HC-1 SERVICES

**Table 3-4** DS1 Compatible Network Channel (NC) Codes

<b>NC CODE</b>	<b>OPTION BR 795-403-100</b>	<b>OPTION Qwest</b>
HCHA	Self-Healing and Disaster Recovery-Loop Protection--One End Only	Self-Healing Protection (One End Only)
HCHE	Self-Healing and Disaster Recovery-Loop and Facility Protection with DS1-DS0/ Subrate Mux (e.g. D4 Format)	DS1-DS0 or Subrate Multiplexing and Self-Healing Protection and Disaster Recovery (SHARP) (One End Only)
HCHC	Self-Healing and Disaster Recovery-Route Protection--DS1-DS0/Subrate Mux (e.g. D4 Format)	DS1-Voice to Digital Data Multiplexing and Self-Healing Protection and Disaster Recovery (SHARP) (One End Only)
HCHS	Self-Healing and Disaster Recovery-Loop and Facilities Protection (i.e. SWC Protection) with DS1 Voice Mux	DS1-Voice Multiplexing and Self-Healing Protection and Disaster Recovery (SHARP) (One End Only), Including Interoffice Protection
HCHD	Self-Healing and Disaster Recovery-Loop (One End) and Facilities Protection (i.e. SWC Protection)	Self-Healing Protection and Disaster Recovery (SHARP) (One End Only) Including Interoffice Protection
HCHI	Self-Healing and Disaster Recovery-Loop Facilities Protection, i.e. SWC Protection with DS1-DS0 Mux (e.g. T1DM e/w Secondary Channel)	DS1-DS0 or Subrate Multiplexing and Self-Healing Protection and Disaster Recovery (SHARP) (One End Only), Including Interoffice Protection
HCH-	Self-Healing and Disaster Recovery-Loop Protection Both Ends of Circuit (w/o Switch Protection)	Self-Healing Protection and Disaster Recovery (SHARP) (Both Ends)
HCHK	Self-Healing and Disaster Recovery-Loop and Facilities Protection, i.e. SWC Protection	Self-Healing Protection and Disaster Recovery (SHARP) (Both Ends), Including Interoffice Protection
HCHL	Self-Healing and Disaster Recovery-Loop Protection Thru Connect Circuit (i.e. CO DSX-1 Term)	Self-Healing Protection and Disaster Recovery (SHARP) (One End Only) and CO Cross-connect at the DS1 Rate
HCHN	Self-Healing and Disaster Recovery-Loop and Facilities Protection (i.e. SWC Protection) for Thru Connect Circuit (i.e. DSX-1 term.)	Self-Healing Protection and Disaster Recovery (SHARP) (One End Only) and CO Cross-connect at the DS1 Rate Including Interoffice Protection

The compatible DS3 NC codes for Qwest Self-Healing Alternate Route Protections Service are listed in Table 3.5.

**Table 3-5 DS3 Compatible Network Channel (NC) Codes HC-3 Services**

<b>NC CODE</b>	<b>OPTION BR 795-403-100</b>	<b>OPTION Qwest</b>
HFHA	Self-Healing Disaster Recovery--Loop Protection--One End Only	Self-Healing Protection and Disaster Recover (SHARP) (One End Only)
HFHB	Self-Healing Disaster Recovery--Loop Protection and B8ZS Compatible CO Mux	B8ZS Compatible CO Multiplexing and Self-Healing Protection and Disaster Recovery (SHARP) (One End Only)
HFHM	Self-Healing Disaster Recovery--Loop Protection and CO Mux	Central Office Multiplexing and Self-Healing Protection and Disaster Recovery (SHARP) (One End Only)
HFH-	Self-Healing Disaster Recovery--Loop and Facility Protection, i.e. SWC Protection	Self-Healing Protection and Disaster Recovery (SHARP) (One End Only), Including Interoffice Protection
HFHI	Self-Healing Disaster Recovery--Loop and Facility Protection (i.e. SWC Protection) with B8ZS Compatible CO Mux	Self-Healing Protection and Disaster Recovery (SHARP) (One End Only), Including Interoffice Protection, CO Multiplexing and B8ZS Compatible
HFHJ	Self-Healing Disaster Recovery--Loop and Facility Protection (i.e. SWC Protection) with CO Mux	Self-Healing Protection and Disaster Recovery (SHARP) (One End Only), Including Interoffice Protection and CO Multiplexing
HFHL	Self-Healing Disaster Recovery--Facility Protection (w/o Loop Protection) Thru Connect Circuit (i.e. CO DSX-3 Term) and Auto Hub Protection	Self-Healing Protection and Disaster Recovery (SHARP) (One End Only) and CO Cross-connect at the DS3 Rate
HFHC	Self-Healing Disaster Recovery--Loop and Facilities Protection (i.e. SWC Protection) for Thru Connect Circuit (i.e. DSX-1)	Self-Healing Protection and Disaster Recovery (SHARP) (One End Only) and CO Cross-connect at the DS3 Rate Including Interoffice Protection
HFHD	Self-Healing Disaster Recovery--Loop Protection Both Ends of Circuit w/o SWC Protection	Self-Healing Protection and Disaster Recovery (SHARP) (Both Ends)
HFHE	Self-Healing Disaster Recovery--Loop (Both Ends) and Facilities Protection (i.e. SWC)	Self-Healing Protection and Disaster Recovery (SHARP) (Both Ends), Including Interoffice Protection

Table 3-5 continues on the following page

**Table 3-5 DS3 Compatible Network Channel (NC) Codes  
HC-3 Services (continued)**

<b>NC CODE</b>	<b>OPTION BR 795-403-100</b>	<b>OPTION Qwest</b>
HFHK	Self-Healing Disaster Recovery-- CO to CO Mux Both Ends	Self-Healing Protection and Disaster Recovery (SHARP) Interoffice Protection Only, Central Office Multiplexing Both Ends
HFHN	Self-Healing Disaster Recovery-- CO to CO Mux Both Ends and B8ZS	Self-Healing Protection and Disaster Recovery (SHARP) Interoffice Protection Only, Central Office Multiplexing and B8ZS Compatible Both Ends
HFHT	Self-Healing Disaster Recovery-- Facility Protection	Self-Healing Protection and Disaster Recovery (SHARP) Interoffice Protection Only
HFHV	Self-Healing Disaster Recovery-- Facility Protection and B8ZS Compatible	Self-Healing Protection and Disaster Recovery (SHARP) Interoffice Protection Only, B8ZS Compatible Both Ends
HFHW	Self-Healing Disaster Recovery-- B8ZS Compatible CO Mux	Self-Healing Protection and Disaster Recovery (SHARP) Interoffice Protection Only, Central Office Multiplexing and B8ZS Compatible One End
HFHX	Self-Healing Disaster Recovery-- Cross Connect	Self-Healing Protection and Disaster Recovery (SHARP) Interoffice Protection Only, Central Office Cross Connect
HFHY	Self-Healing Disaster Recovery-- W + X--B8ZS Compatible and Cross Connect	Self-Healing Protection and Disaster Recovery (SHARP) Interoffice Protection Only, Central Office Multiplexing and B8ZS Compatible One End and Central Office Cross Connect

## CONTENTS

<b>Chapter and Section</b>	<b>Page</b>
4. Performance Specifications.....	4-1
4.1 Error Performance Parameters .....	4-1
4.2 Error Performance Requirements .....	4-1
4.3 Service Availability .....	4-2
4.4 Jitter Performance .....	4-2
4.4.1 Definition Of Timing Jitter .....	4-2
4.4.2 Network Interface Timing Jitter Specifications .....	4-2
4.5 Protection Switching.....	4-2



## 4. Performance Specifications

### 4.1 Error Performance Parameters

The parameters for which performance is specified are as follows:

- Bit Error Rate (BER) - The BER is the ratio of the number of bits in error to the total number of bits transmitted during a measurement period.
- Errored Seconds - An Errored Second is any one second interval containing at least one error.
- Burst Errored Seconds - A Burst Errored Second is any Errored Second containing at least 100 errors.

### 4.2 Error Performance Requirements

The requirements given in this section are for all one-way system options and apply at the maximum short-haul design length of 250 miles. For shorter systems, the numerical values are to be reduced in direct proportion to route mileage. A measurement period consists of a series of one-second intervals.

The BER at the DS1 and DS3 interface levels will be  $\leq 1 \times 10^{-9}$  excluding all Burst Errored Seconds in the measurement period. During a Burst Errored Second, neither the number of bit errors nor the number of bits is counted. This requirement applies in a normal operating environment, and should be met by every channel in each protection switching section.

The frequency of Burst Errored Seconds, other than those caused by protection switching induced by hard equipment failures, should average no more than 4 per day at the interface levels of DS1 and DS3. This requirement applies in a normal operating environment, and should be met by every channel in each protection switching section.

For systems interfacing at the DS3 level, the long-term percentage of Errored Seconds should not exceed 1.0%. This is equivalent to 99.0% Error Free Seconds (EFS). This requirement applies in a normal operating environment, and it is also an acceptance criterion. It equates to no more than 72 Errored Seconds during a two-hour one-way (loopback) test.

For systems interfacing at the DS1 level, the long-term percentage of Errored Seconds should not exceed 0.14%. This is equivalent to 99.86% EFS. This requirement applies in a normal operating environment, and it is also an acceptance criterion. It equates to no more than 10 Errored Seconds during a two-hour one-way (loopback) test.

Loopback acceptance tests should be made using the one-way limits because one direction is likely to be controlling. If these fail, then appropriate one-way tests should be made.

### 4.3 Service Availability

The availability requirement for Qwest Self-Healing Alternate Route Protection Service (SHARP and SHARP Plus) is 99.99 percent. Unavailability is defined as any one second interval with a line BER worse than  $1 \times 10^{-3}$ . The corresponding outage equates to 52 minutes per year.

The availability requirement of 99.99% only applies to the portion of a circuit protected by Qwest Self-Healing Alternate Route Protection Service. The standard availability requirement will apply for any portion of the circuit transported over non-SHARP circuits.

### 4.4 Jitter Performance

#### 4.4.1 Definition Of Timing Jitter

Timing jitter is defined as the short term variations of the significant instances of a digital signal from their ideal positions in time, where short term implies phase oscillations of frequency greater than or equal to 10 Hertz.

#### 4.4.2 Network Interface Timing Jitter Specifications

The limits given in Telcordia GR- 499-CORE, "Transport Systems Generic Requirements (TSGR): Common Requirements (A Module of TSGR, FR-NWT-000440)" represent the maximum permissible levels of output jitter for Carrier-to-Carrier Network Interfaces. The Carrier-to-End User Network Interface jitter requirements are addressed in ANSI T1.404-2002. The purpose of these limits is to limit broadband jitter appearing anywhere in the Qwest Corporation Network.

### 4.5 Protection Switching

Automatic protection switching is used to improve the availability and reliability performance of Qwest Self-Healing Alternate Route Protection Service by substituting standby equipment or alternate channels when failure occurs.

The protection switch will operate and switch the Qwest DS3 or DS1 channel to the protection system when the BER on the transport system reaches  $1 \times 10^{-6}$  and operates at that BER for 10 consecutive seconds.

Once a decision is made to switch to a protection system, the additional time required to complete the switch will not exceed 50 milliseconds.

## CONTENTS

<b>Chapter and Section</b>	<b>Page</b>
5. Maintenance .....	5-1
5.1 Customer Responsibilities.....	5-1
5.2 Qwest Responsibilities.....	5-1



## **5. Maintenance**

### **5.1 Customer Responsibilities**

The customer is responsible for all equipment and cable on the customer side of the NI at their location.

The customers or their responsible agent must sectionalize the trouble and verify that the trouble is not in the customer owned equipment or cable before calling the Qwest Customer Service Center (CSC).

If the trouble is isolated to the customer owned equipment or cable, the customer is responsible for clearing the trouble and restoring the service to normal.

Joint testing between the customer location and a Qwest may sometimes be necessary to isolate the trouble.

### **5.2 Qwest Responsibilities**

Qwest is responsible for all equipment and cable on the Qwest side of the NI at the customer's location.

Qwest is responsible for maintaining the transmission facility between customer locations and between the Central Office Hub and the customer location.

Qwest will furnish the customer a trouble reporting telephone number.

Upon receipt of a trouble report, Qwest Corporation will initiate action within twenty minutes to clear the trouble.

Qwest is committed to 30 minute restoral in the event of a service interruption on Self-Healing Alternate Route Protection (SHARP) Services with the following two exceptions:

- Two (2) hours maximum restoral time in the event that the working or protection path fails as a result of an electronics failure.
- Eight (8) hours maximum restoral time if the path failure is a result of a cable failure.

## CONTENTS

<b>Chapter and Section</b>	<b>Page</b>
6. Definitions.....	6-1
6.1 Acronyms.....	6-1
6.2 Glossary .....	6-2



## 6. Definitions

### 6.1 Acronyms

ANSI	American National Standards Institute
AWC	Alternate Wire Center
B8ZS	Bipolar with 8 Zero Substitution
BER	1) Basic Encoding Rules for ASN.1 2) Bit Errored Ratio 3) Bit Error Rate
CPE	Customer Provided Equipment
CO	Central Office
CSC	Customer Service Center
EU	End User
FC	Fiber Connector
FDP	Fiber Distribution Panel
IEC	Interexchange Carrier (or IC) Interexchange Common Carrier
INE	Intelligent Network Element or Equipment
ITU-T	International Telecommunication Union - Telecommunication Standardization Sector
LC	Lucent or Local Connector
LEC	Local Exchange Carrier
NC	Network Channel
NCI	Network Channel Interface
NI	Network Interface
POP	Point Of Presence
POT	Point Of Termination
SC	Subscriber Connector
SHARP	Self-Healing Alternate Route Protection
SHNS	Self-Healing Network Services
SHS	Self-Healing Services
SONET	Synchronous Optical Network

SOT	SONET Optical Terminal
SWC	Serving Wire Center
TIA/EIA	Telecommunications Industry Association/Electronic Industries Alliance
µm	Micron
UPC	Ultra Physical Contact

## 6.2 Glossary

### **Alternate Mark Inversion (AMI)**

A one (mark) pulse which is the opposite polarity as its predecessor.

### **American National Standard Institute (ANSI)**

An organization supported by the telecommunications industry to establish performance and interface standards.

### **Automatic Protection Switch (APS)**

A device which monitors a channel and automatically switches the channel to another facility whenever the channel fails or when specified parameters go beyond a specified threshold.

### **Availability**

The relative amount of time that a service is "usable" by a customer, represented as a percentage over a consecutive 12 month period.

### **Bipolar With 8 Zero Substitution (B8ZS)**

Bipolar 8 Zero Substitution is an application of BPRZ and is an exception to the Alternate Mark Inversion (AMI) line-code rule. It is one method of providing bit independence for digital transmission by providing a minimum 1s density of 1 in 8 bits.

### **Bit (Binary Digit)**

A binary unit of information. It is represented by one of two possible conditions, such as the value 0 or 1, on or off, high potential or low potential, conducting or not conducting, magnetized or demagnetized. A Bit is the smallest unit of information, by definition.

### **Bits/second (bit/s)**

Bits per second, e.g., 1200 bps. In data transmission, it is the number of binary zero and one bits transmitted in 1 second. Modern terminology uses "bit/s" e.g., 1200 bit/s.

**Bit Error Rate (BER)**

The ratio of the number of bit errors to the total number of bits transmitted in a given time interval.

**Carrier**

An organization whose function is to provide telecommunications services. Examples are: Local Exchange Carriers, Interexchange Carriers, Cellular Carriers, etc.

**Central Office (CO)**

A local switching system (or a portion thereof) and its associated equipment located at a wire center.

**Channel**

An electrical or photonic, in the case of fiber optic based transmission systems, communications path between two or more points of termination.

**Channelize**

The process of multiplexing-demultiplexing channels using analog or digital techniques.

**Clear Channel Capability (CCC)**

A characteristic of a transmission path in which the bit positions allocated for customer data may represent any combination of zeroes and ones.

**Customers**

Denotes any individual, partnership or corporation who subscribes to the services provided by Qwest customers are divided into two distinct and separate categories: (1) carriers, who provide interexchange services for hire for others, and (2) end-users, who request services only for their own use.

**Customer Installation (CI)**

Equipment and wiring at the customer's location on the customer side of the Network Interface.

**Customer Interface**

The interface with a customer at a point of termination.

### **Customer Premises**

Denotes a building or portion(s) of a building occupied by a single customer or end-user either as a place of business or residence. Adjacent buildings and the buildings on the same continuous property occupied by the customer and not separated by a public thoroughfare, are also considered the customer's premises.

### **Customer Premises Equipment (CPE)**

All telecommunication equipment located at a customer's location.

### **Customer Provided Equipment (CPE)**

Equipment owned and maintained by the customer and located on their side of the End-User Point of Termination (EU-POT) network interface. In the Qwest Digital Data Service application, CPE typically includes the DSU (CSU/DSU) and data terminal equipment which are connected to the channel.

### **Demarcation Point**

See Network Interface

### **Demultiplexing**

The opposite of multiplexing. That is, the multiplexer combines signals and the demultiplexer takes them apart again. Also see Multiplexing.

### **Digital Transmission Facilities**

May include both loop and interoffice facilities which perform multiplexing, demultiplexing, and transport of digital signals between the SS Exchange Termination and the Subscriber Access Termination.

### **DS1 Clear Channel**

Denotes that 1.535 Mbit/s of a 1.544 Mbit/s DS1 facility are available for customer information. The remaining 8 kilobits, or overhead, are for error correction, framing, and network performance/status/information.

### **End Office**

A designation of a Qwest switching system that occupies the lowest level of the public switched network hierarchy. It is the designation of a switching system that connects lines to lines, and lines to trunks (a local switching system).

### **End-User (EU)**

The term "end-user" denotes any customer of telecommunications service that is not a carrier, except that a carrier shall be deemed to be an "end-user" to the extent that such carrier uses a telecommunications service for administrative purposes without making such service available to others, directly or indirectly. The term is frequently used to denote the difference between a Carrier interface and an interface subject to unique regulatory requirements at non-Carrier customer premises (FCC Part 68, etc.)

### **Error Free Second (EFS)**

A one-second interval which does not contain any bit-errors. Usually expressed as a percent over a consecutive 24-hour period.

### **Errored Second (ES)**

A one second interval with one or more bit errors.

Note - A period of no signal shall be considered a period of errored bits.

### **Exchange**

A unit established by Qwest for the administration of communications service in a specified geographic area that usually embraces a city, town, or village and its environs.

### **Expected Measured Loss (EML)**

The calculated value of loss at a given reference frequency that one would expect to measure between two specified test points with the proper terminating impedance.

### **Extended Superframe (ESF) Format**

An Extended Superframe consists of twenty-four consecutive DS1 frames. Bit one of each frame (the F-bit) is time shared during the 24 frames to describe a 6 bit frame pattern, a 6 bit Cyclic Redundancy Check (CRC) remainder, and a 12 bit data link. The transfer rate of each is 2 kbit/s, 2 kbit/s, and 4 kbit/s respectively.

### **Facilities**

Facilities are the transmission paths between the demarcation points serving customer locations, a demarcation point serving a customer location and a Qwest Central Office, or two Qwest offices.

### **Fiber Optic Terminal (FOT)**

The terminating or originating portion of a fiber optic system that performs both an electrical to optical conversion and a multiplexing function.

**Intelligent Network Element (INE)**

A software programmable network component.

**Interexchange Carrier (IC)/(IEC) or Interexchange Common Carrier**

Any individual, partnership, association, joint-stock company, trust, governmental entity or corporation engaged for hire in interstate or foreign communication by wire or radio, between two LATAs.

**Interface Code**

See Network Channel Interface

**Isochronous Transmission**

A transmission process in which there is always an integral number of unit intervals between any two significant instants. The transmission is characterized by a constant pulse rate, a constant time interval, or multiples thereof between voltage or electromagnetic field intensity transitions, and a gating by a controlled clock.

**Jitter**

Random timing distortions of a digital signal, whereby the appearance of a pulse differs from where the pulse should occur relative to time.

**Kilobit/Second (kbit/s)**

One thousand (1000) bits/second  
management functions.

**Line**

The transport facility (cable pair or carrier channel) between the Central Office and Network Channel Interface.

**Local Exchange Carrier (LEC)**

The regulated entity providing Access and Intra-LATA services.

**Multiplexer (Mux)**

An equipment unit to multiplex, or do multiplexing: Multiplexing is a technique of modulating (analog) or interleaving (digital) multiple, relatively narrow bandwidth channels into a single channel having a wider bandwidth (analog) or higher bit-rate (digital). the term Multiplexer implies the demultiplexing function is present to reverse the process so it is not usually stated.

### **Network Channel (NC) Code**

The Network Channel (NC) code is an encoded representation used to identify both switched and non-switched channel services. Included in this code set are customer options associated with individual channel services, or feature groups and other switched services.

### **Network Channel Interface (NCI) Code**

The Network Channel Interface (NCI) code is an encoded representation used to identify five (5) interface elements located at a Point of Termination (POT) at a central office or at the Network Interface at a customer location. The Interface code elements are: Total Conductors, Protocol, Impedances, Protocol Options, and Transmission Level Points (TLP). (At a digital interface, the TLP element of the NCI code is not used.)

### **Network Interface (NI)**

The point of demarcation on the customer's premises at which Qwest's responsibility for the provision of service ends.

### **Optical Carrier (OC)**

Optical carrier, the nomenclature for the line rate of the optical transmission signal described in this document.

### **Optical Interface (OI)**

The OI is the transmit point wherein light waves move away from the interface toward an optical receiver.

### **Phase Jitter**

Intermittent, random displacements in time of digital bits, from their ideal placement in time.

### **Point of Presence (POP)**

A physical location within a LATA at which an Interexchange Carrier (IC) establishes itself for the purpose of obtaining LATA access and to which Qwest provides access service.

### **Point of Termination (POT)**

The physical telecommunications interface that establishes the technical interface, the test point(s), and the point(s) of operational responsibility. (See Network Interface).

### **Premises**

Denotes a building or portion(s) of a building occupied by a single customer or end-user either as a place of business or residence.

### **Protocol**

The rules for communication system operation which must be followed if communication is to be effected; the complete interaction of all possible series of messages across an interface. Protocols may govern portions of a network, types of service, or administrative procedures.

### **Protocol Code**

The Protocol (character positions 3 and 4 or the Network Channel Interface [NCI] Code) is a two-character alpha code that defines requirements for the interface regarding signaling and transmission.

### **Serving Wire Center**

The term "Serving Wire Center" denotes a Qwest Central Office from which dial tone for the local Exchange Service would normally be provided to the demarcation point on the property at which the customer is served.

### **Severely Errored Second (SES)**

A one second interval having a Bit Error Ratio of  $10^{-3}$  or worse

### **SONET**

Synchronous Optical Network (SONET): A standard providing electrical and optical specifications for the physical and higher layers, the first stage of which is at 51.84 Mbit/s, the Optical Channel 1 (OC1) level. Other rates, defined as OC $n$  where  $n=3$  through a number not yet firm, are possible.

### **SONET Optical Terminal (SOT)**

A terminal which uses SONET multiplexing to interleave the lower rate payloads, thereby creating a high rate synchronous signal.

### **Superframe Format (SF)**

A superframe consists of 12 consecutive DS1 frames. Bit one of each frame (the F-bit) is used to describe a 12-bit framing pattern during the 12 frames.

### **Synchronous Optical Network (SONET)**

A standard providing electrical and optical specifications for the physical and higher layers, the first stage of which is at 51.84 Mbit/s, the Optical Channel 1 (OC-1) level. Other rates, defined as OC- $n$  where  $n=3$  through a number not yet firm, are possible.

### **Synchronous Test Line**

An arrangement in a central office that performs marginal operational tests of supervisory and ring-tripping functions.

### **Synchronous Transmission**

A transmission process such that between any two significant instants in the overall bit-stream there is always an integral number of unit intervals.

### **Transmission Path**

Denotes a path capable of transporting signals within the range of the service offering. A transmission path is comprised of physical or derived facilities consisting of any form or configuration of plant typically used in the telecommunications industry.

### **Transmission Service Channel**

A one-way transmission path between two designated points.

### **Trunk**

A communications path connecting two switching systems in a network, used in the establishment of an end-to-end connection.

### **Wire Center**

A building in which one or more central offices, used for the provision of local exchange services, are located.

### **ZBTSI**

A method of providing DS1 Clear Channel Capability using the Extended Superframe (ESF) format and Alternate Mark Inversion (AMI) line code. See ANSI T1.107-1988.

## CONTENTS

<b>Chapter and Section</b>	<b>Page</b>
7. References.....	7-1
7.1 American National Standards Institute Documents.....	7-1
7.2 Telcordia Documents .....	7-1
7.3 International Telecommunication Union - Telecommunication Standardization Sector (ITU-T) Recommendations.....	7-2
7.4 Qwest Technical Publications .....	7-2
7.5 Ordering Information .....	7-2
7.6 Trademarks .....	7-3



## 7. References

### 7.1 American National Standards Institute Documents

ANSI T1.102-1993 (R1999)	<i>Digital Hierarchy – Electrical Interfaces</i>
ANSI T1.105-2001	<i>Synchronous Optical Network (SONET) - Basic Description including Multiplex Structure, Rates, and Formats</i>
ANSI T1.107-2002 (R2006)	<i>Digital Hierarchy – Formats Specifications</i>
ANSI T1.223-2004	<i>Structure and Representation of Network Channel (NC) and Network Channel Interface (NCI) Codes for information exchanges</i>
ANSI T1.403-1999	<i>Network and Customer Installation Interfaces – DS1 Electrical Interface</i>
ANSI T1.403b-2002 (R2005)	<i>Supplement to T1.403-1999</i>
ANSI T1.404-2002 (R2006)	<i>Network and Customer Installation Interfaces -- DS3 Metallic Interface Specification</i>
ANSI/TIA-492AAAA-B-2009	<i>Detail Specification for 62.5-<math>\mu</math>m Core Diameter/125-<math>\mu</math>m Cladding Diameter Class Ia Graded-Index Multimode Optical Fibers</i>
ANSI/TIA-492AAAB-A-2009	<i>Detail Specification for 50-<math>\mu</math>m Core Diameter/125-<math>\mu</math>m Cladding Diameter Class Ia Graded-Index Multimode Optical Fibers</i>
ANSI/TIA/EIA-570-B-2010	<i>Residential Telecommunications Cabling Standard</i>
ANSI/TIA/EIA-758-A-2004	<i>Customer-Owned Outside Plant Telecommunications Cabling Standard</i>

### 7.2 Telcordia Documents

GR-20-CORE	<i>Generic Requirements for Optical Fiber and Fiber Optical Cable</i>
GR- 342-CORE	<i>High-Capacity Digital Special Access Service-Transmission Parameter Limits and Interface Combinations</i>
GR-499-CORE	<i>Transport Systems Generic Requirements (TSGR): Common Requirements</i>

### 7.3 International Telecommunication Union - Telecommunication Standardization Sector (ITU-T) Recommendations

G.652 *Characteristics of a single-mode optical fibre and cable*

### 7.4 Qwest Technical Publications

PUB 77200 *Qwest DS1 Service and Qwest DS1 Rate Synchronization Service, Network Channel and Network Channel Interface Code Combinations, Issue F, September 2001*

PUB 77324 *Qwest DS-3 Service, Issue F, January 2005*

PUB 77346 *Qwest Synchronous Service Transport(SST), Issue T, January 2011*

PUB 77368 *CUSTOMER PREMISES ENVIRONMENTAL SPECIFICATIONS AND INSTALLATION GUIDE, Issue F, July 2009*

PUB 77375 *Qwest 1.544 Mbit/s Channel Interfaces, Issue G, June 2008*

PUB 77386 *Interconnection and Collocation for Transport and Switched Unbundled Network Elements and Finished Services, Issue M, October 2007*

PUB 77419 *SPECIFICATIONS FOR THE PLACEMENT OF QWEST EQUIPMENT IN CUSTOMER-OWNED OUTDOOR CABINETS, Issue A, June 2010*

### 7.5 Ordering Information

All documents are subject to change and their citation in this document reflects the most current information available at the time of printing. Readers are advised to check status and availability of all documents.

Those who are not Qwest employees may obtain;

- ANSI documents from:

American National Standards Institute  
Attn: Customer Service  
11 West 42nd Street  
New York, NY 10036  
Phone: (212) 642-4900  
Fax: (212) 302-1286  
Web: <http://www.ansi.org/>

ANSI has a catalog available which describes their publications.

- Telcordia documents from:

Telcordia Customer Relations  
8 Corporate Place, PYA 3A-184  
Piscataway, NJ 08854-4156  
Fax: (732) 699-2559  
Phone: (800) 521-CORE (2673) (U.S. and Canada)  
Phone: (908) 699-5800 (Others)  
Web: <http://www.telcordia.com>

- ITU-T Recommendations from:

International Telecommunications Union  
General Secretariat  
Place des Nations, CH-1211  
Geneva 20, Switzerland  
Web: <http://www.itu.int/home/>

- Qwest Technical Publications from:

<http://www.qwest.com/techpub/>

## 7.6 Trademarks

Qwest                      Registered Trademark of Qwest Communications International, Inc.