

## Batch Hot Cut Status Update Table of Contents

<b>17.</b>	<b>BATCH HOT CUT STATUS UPDATE</b> .....	<b>2</b>
17.1	BUSINESS MODEL.....	2
17.1.1	Push Transaction Process.....	2
17.1.2	Pull Transaction Process.....	3
17.2	BATCH HOT CUT SCHEMA.....	4

# 17. Batch Hot Cut Status Update

## 17.1 Business Model

### Batch Hot Cut Status (BHC) Normal Transaction Flow

The following diagram depicts a normal Batch Hot Cut Status (BHC) transaction flow. A normal transaction flow means:

- Outbound only transaction from Qwest
- Transaction information contains Batch Hot Cut Status notification detail for LSR service orders that contained a batch hot cut request.

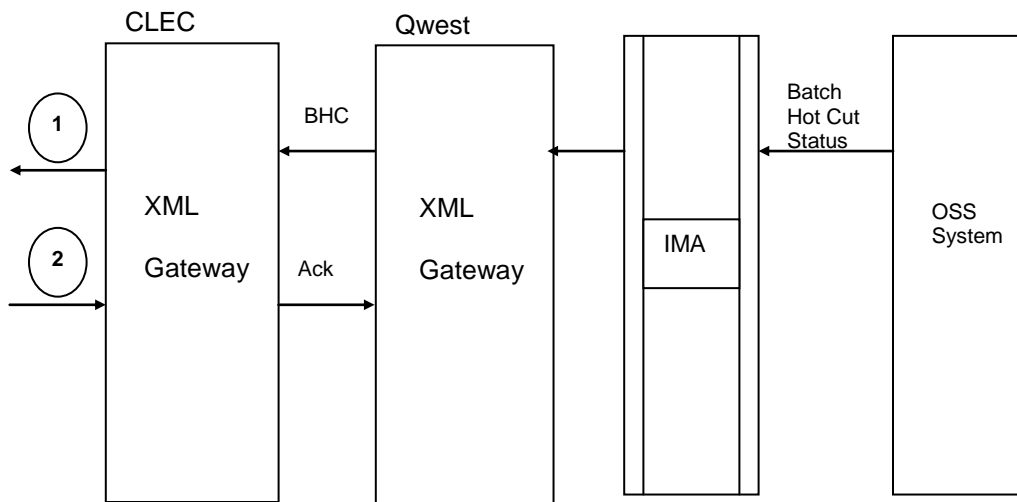

#### 17.1.1 Push Transaction Process

1. The OSS system identifies that there has been activity with a service order and is still in a pending state or has been completed. After CLEC subscription to the Batch Hot Cut Notice (BHC) is verified, BHC status detail is sent to IMA. The IMA gateway is a middleware that performs order content edits and interacts with the Operating Support System (OSS). The IMA gateway formats and forwards the BHC message to the IMA XML Gateway. Qwest opens an asynchronous connection to the CLEC and then transports the transaction to the CLEC's XML Gateway.
2. An Acknowledgment from the CLEC will be returned to the Qwest IMA XML Gateway to confirm receipt of the BHC transaction. If an Acknowledgement is not returned, the BHC transactions will be made available for Pull.

### **17.1.2 Pull Transaction Process**

1. The OSS system identifies that there has been activity with a service order and is still in a pending state or has been completed. After CLEC subscription to the Batch Hot Cut Status Updates (BHC) is verified, BHC status detail is sent to IMA. The IMA gateway formats and forwards the BHC to the IMA XML Gateway, where the transaction will be available to be pulled.
2. The CLEC will initiate a Pull request for up to the maximum number of notices. The Pull request will retrieve all post-order notices waiting to be pulled.
3. The CLEC will send an individual acknowledgement to Qwest IMA XML Gateway for each transaction they pick up. Even though the BHC can be pulled when available (outside normal business hours) the acknowledgement for the BHC can not be sent until normal business hours. If an acknowledgement is not received within 24 hours the BHC will be made available for Pull again the next day. This process will be repeated until an acknowledgement is received.

## **17.2 Batch Hot Cut Schema**

Please see Appendix H – WSDL – Post Order.