

Status Updates – Auto Push

Table of Contents

25. STATUS UPDATE – AUTO PUSH	2
25.1 BUSINESS MODEL	2
25.1.1 Push Transaction Process	2
25.1.2 Pull Transaction Process	3
25.2 STATUS UPDATE SCHEMA	4

25. Status Update – Auto Push

25.1 Business Model

Status Update (SU) Normal Transaction Flow

The following diagram depicts a normal Status Updates – Auto Push (SU) transaction flow. The Status Updates allows the CLEC to receive information regarding the status of an order that has a “highly significant” status change. A normal transaction flow means:

- Outbound only transaction from Qwest
- Transaction information contains status update change detail for LSR and/or service orders that have changed.

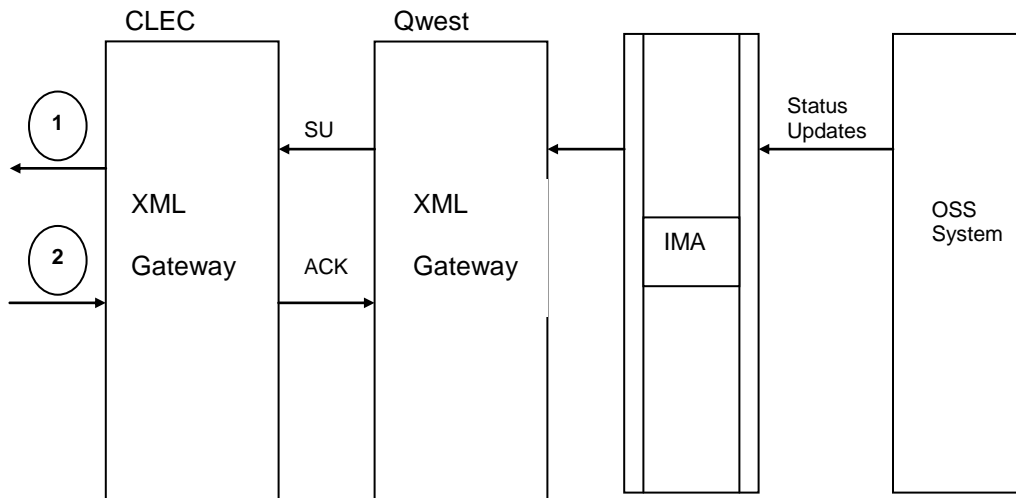

25.1.1 Push Transaction Process

1. The OSS system identifies that there has been activity with a service order and is still in a pending state or has been completed. After CLEC subscription to the Status Updates (SU) is verified, SU transaction detail is sent to IMA. The IMA gateway is a middleware that performs order content edits and interacts with the Operating Support System (OSS). The IMA gateway formats and forwards the SU message to the IMA XML Gateway. Qwest opens an asynchronous connection to the CLEC and then transports the transaction to the CLEC’s XML Gateway.
2. An Acknowledgment from the CLEC will be returned to the Qwest IMA XML Gateway to confirm receipt of the SU transaction. If an Acknowledgement is not returned, the SU transactions will be made available for Pull.

25.1.2 Pull Transaction Process

1. The OSS system identifies that there has been activity with a service order and is still in a pending state or has been completed. After CLEC subscription to the Status Updates (SU) is verified, SU detail is sent to IMA. The IMA gateway formats and forwards the SU to the IMA XML Gateway, where the transaction will be available to be pulled.
2. The CLEC will initiate a Pull request for up to the maximum number of notices. The Pull request will retrieve all post-order notices waiting to be pulled.
3. The The CLEC will send an individual acknowledgement to Qwest IMA XML Gateway for each transaction they pick up. If an acknowledgement is not received within 24 hours the SU will be made available for Pull again the next day. This process will be repeated until an acknowledgement is received.

25.2 Status Update Schema

Please see Appendix H – WSDL – Post Order.