



Pending Service Order Notice Table of Contents

22.	PENDING SERVICE ORDER NOTICE	2
22.1	BUSINESS MODEL	2
22.1.1	Push Transaction Process	2
22.1.2	Pull Transaction Process	3
22.2	PENDING SERVICE ORDER NOTICE SCHEMA	4

22. Pending Service Order Notice

22.1 Business Model

Pending Service Order Notice (PSON) Normal Transaction Flow

The following diagram depicts a normal Pending Service Order Notice (PSON) transaction flow. The Pending Service Order Notice allows the CLEC to receive current information on service order activity. A normal transaction flow means:

- Outbound only transaction from Qwest
- Transaction information contains pending service order detail for service orders that are still in progress or have been completed.

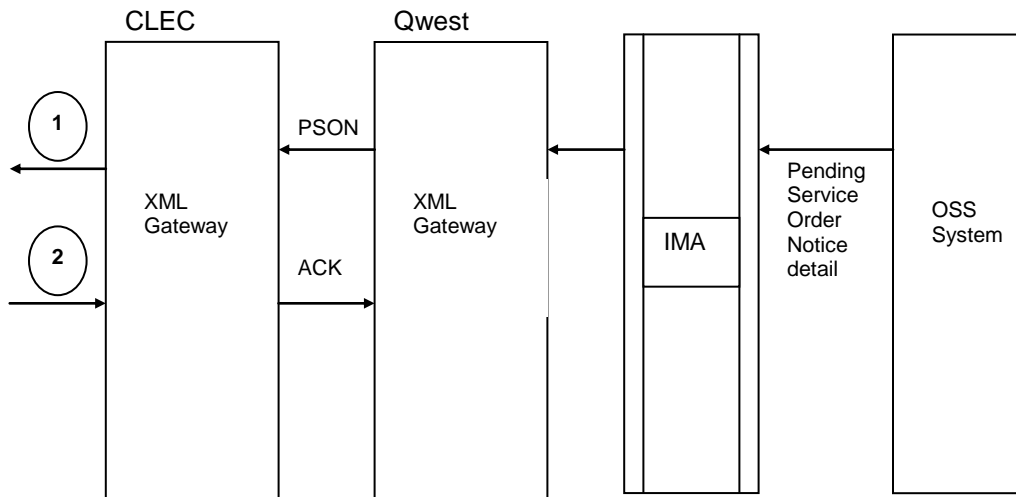

22.1.1 Push Transaction Process

1. The OSS system identifies that there has been activity with a service order and is still in a pending state or has been completed. After CLEC subscription to the Pending Service Order Notification (PSON) is verified, PSON status detail is sent to IMA. The IMA gateway is a middleware that performs order content edits and interacts with the Operating Support System (OSS). The IMA gateway formats and forwards the PSON message to the IMA XML Gateway. Qwest opens an asynchronous connection to the CLEC and then transports the transaction to the CLEC's XML Gateway.
2. An Acknowledgment from the CLEC will be returned to the Qwest IMA XML Gateway to confirm receipt of the PSON transaction. If an Acknowledgement is not returned the PSON transactions will be made available for Pull.

22.1.2 Pull Transaction Process

1. The OSS system identifies that there has been activity with a service order and is still in a pending state or has been completed. After CLEC subscription to the Pending Service Order Notification (PSON) is verified, PSON status detail is sent to IMA. The IMA gateway formats and forwards the PSON to the Qwest IMA XML Gateway, where the transaction will be available to be pulled.
2. The CLEC will initiate a Pull request for up to the maximum number of notices. The Pull request will retrieve all post-order notices waiting to be pulled.
3. The CLEC will send an individual acknowledgement to the Qwest IMA XML Gateway for each transaction they pick up. If an acknowledgement is not received within 24 hours the PSON will be made available for Pull again the next day. This process will be repeated until an acknowledgement is received.

22.2 Pending Service Order Notice Schema

Please see Appendix H – WSDL – Post Order.