

Billing Completion Notice

Table of Contents

18.	BILLING COMPLETION NOTICE.....	2
18.1	BUSINESS MODEL	2
18.1.1	Push Transaction Process.....	2
18.1.2	Pull Transaction Process.....	3
18.2	BILLING COMPLETION NOTICE SCHEMA	4

18. Billing Completion Notice

18.1 Business Model

Billing Completion Notice (BCN) Normal Transaction Flow

The following diagram depicts a normal Billing Completion Notice (BCN) transaction flow. A normal transaction flow means:

- Outbound only transaction from Qwest
- Transaction information contains billing completion notification detail for LSR service orders that have been posted to be billed.

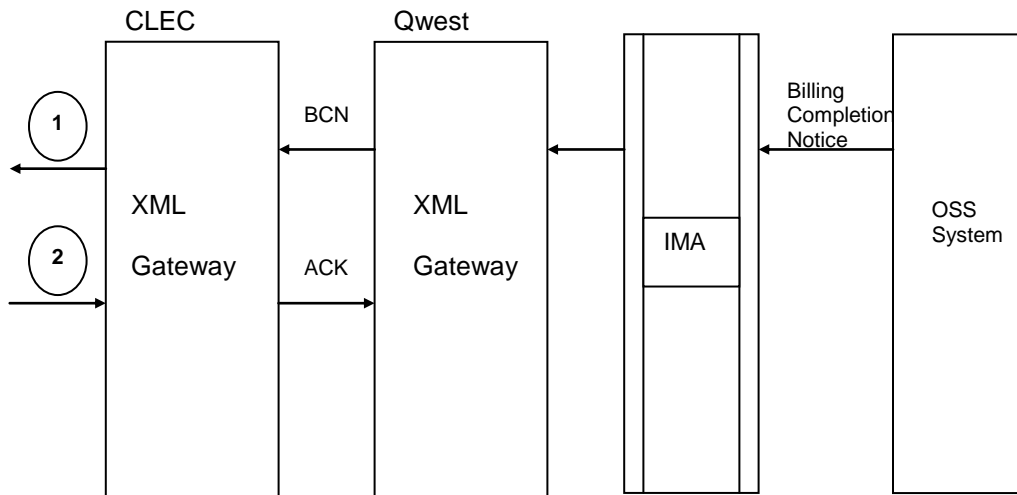

18.1.1 Push Transaction Process

1. The OSS system identifies that there has been activity with a service order and is still in a pending state or has been completed. After CLEC subscription to the Billing Completion Notice (BCN) is verified, BCN status detail is sent to IMA. The IMA gateway is a middleware that performs order content edits and interacts with the Operating Support System (OSS). The IMA gateway formats and forwards the BCN message to the IMA XML Gateway. Qwest opens an asynchronous connection to the CLEC and then transports the transaction to the CLEC's XML Gateway.
2. An Acknowledgment from the CLEC will be returned to the Qwest IMA XML Gateway to confirm receipt of the BCN transaction. If an Acknowledgement is not returned, the BCN transactions will be made available for Pull.

18.1.2 Pull Transaction Process

1. The OSS system identifies that there has been activity with a service order and is still in a pending state or has been completed. After CLEC subscription to the Billing Completion Notice (BCN) is verified, BCN status detail is sent to IMA. The IMA gateway formats and forwards the BCN to the IMA XML Gateway, where the transaction will be available to be pulled.
2. The CLEC will initiate a Pull request for up to the maximum number of notices. The Pull request will retrieve all post-order notices waiting to be pulled.
3. The CLEC will send an individual acknowledgement to Qwest IMA XML Gateway for each transaction they pick up. If an acknowledgement is not received within 24 hours the BCN will be made available for Pull again the next day. This process will be repeated until an acknowledgement is received.

18.2 Billing Completion Notice Schema

Please see Appendix H – WSDL – Post Order.